

Chapter 10

Liquids and Solids

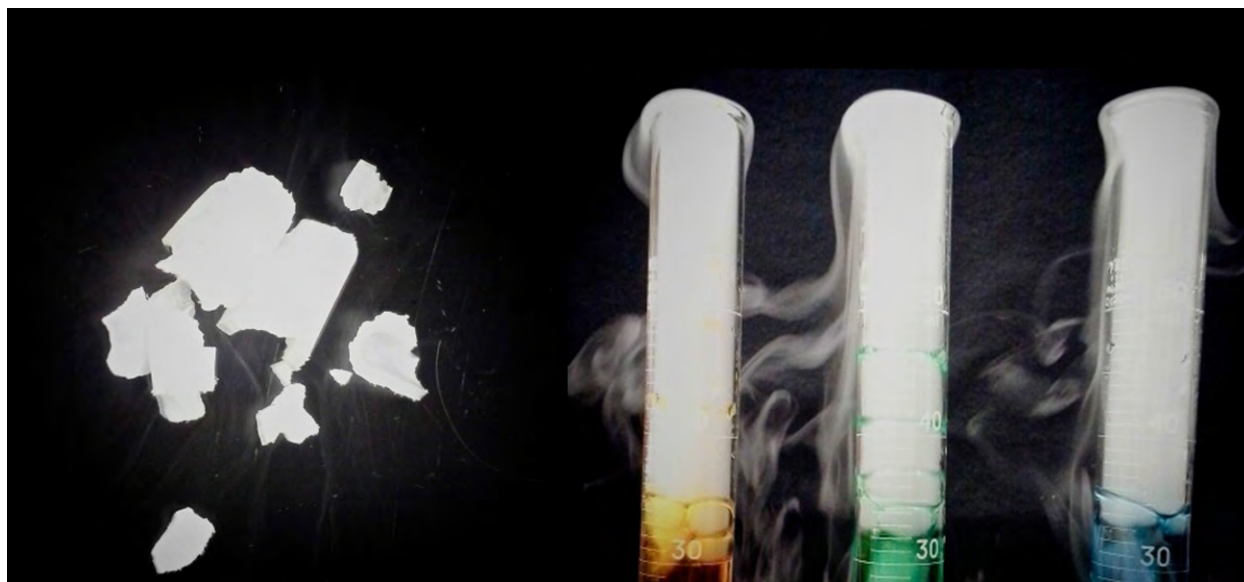

Figure 10.1 Solid carbon dioxide (“dry ice”, left) sublimates vigorously when placed in a liquid (right), cooling the liquid and generating a fog of condensed water vapor above the cylinder. (credit: modification of work by Paul Flowers)

Chapter Outline

- 10.1 Intermolecular Forces
- 10.2 Properties of Liquids
- 10.3 Phase Transitions
- 10.4 Phase Diagrams
- 10.5 The Solid State of Matter
- 10.6 Lattice Structures in Crystalline Solids

Introduction

The great distances between atoms and molecules in a gaseous phase, and the corresponding absence of any significant interactions between them, allows for simple descriptions of many physical properties that are the same for all gases, regardless of their chemical identities. As described in the final module of the chapter on gases, this situation changes at high pressures and low temperatures—conditions that permit the atoms and molecules to interact to a much greater extent. In the liquid and solid states, these interactions are of considerable strength and play an important role in determining a number of physical properties that *do* depend on the chemical identity of the substance. In this chapter, the nature of these interactions and their effects on various physical properties of liquid and solid phases will be examined.

10.1 Intermolecular Forces

By the end of this section, you will be able to:

- Describe the types of intermolecular forces possible between atoms or molecules in condensed phases (dispersion forces, dipole-dipole attractions, and hydrogen bonding)
- Identify the types of intermolecular forces experienced by specific molecules based on their structures
- Explain the relation between the intermolecular forces present within a substance and the temperatures associated with changes in its physical state

As was the case for gaseous substances, the kinetic molecular theory may be used to explain the behavior of solids and liquids. In the following description, the term *particle* will be used to refer to an atom, molecule, or ion. Note that we will use the popular phrase “intermolecular attraction” to refer to attractive forces between the particles of a substance, regardless of whether these particles are molecules, atoms, or ions.

Consider these two aspects of the molecular-level environments in solid, liquid, and gaseous matter:

- Particles in a solid are tightly packed together and often arranged in a regular pattern; in a liquid, they are close together with no regular arrangement; in a gas, they are far apart with no regular arrangement.
- Particles in a solid vibrate about fixed positions and do not generally move in relation to one another; in a liquid, they move past each other but remain in essentially constant contact; in a gas, they move independently of one another except when they collide.

The differences in the properties of a solid, liquid, or gas reflect the strengths of the attractive forces between the atoms, molecules, or ions that make up each phase. The phase in which a substance exists depends on the relative extents of its **intermolecular forces** (IMFs) and the kinetic energies (KE) of its molecules. IMFs are the various forces of attraction that may exist between the atoms and molecules of a substance due to electrostatic phenomena, as will be detailed in this module. These forces serve to hold particles close together, whereas the particles' KE provides the energy required to overcome the attractive forces and thus increase the distance between particles. **Figure 10.2** illustrates how changes in physical state may be induced by changing the temperature, hence, the average KE, of a given substance.

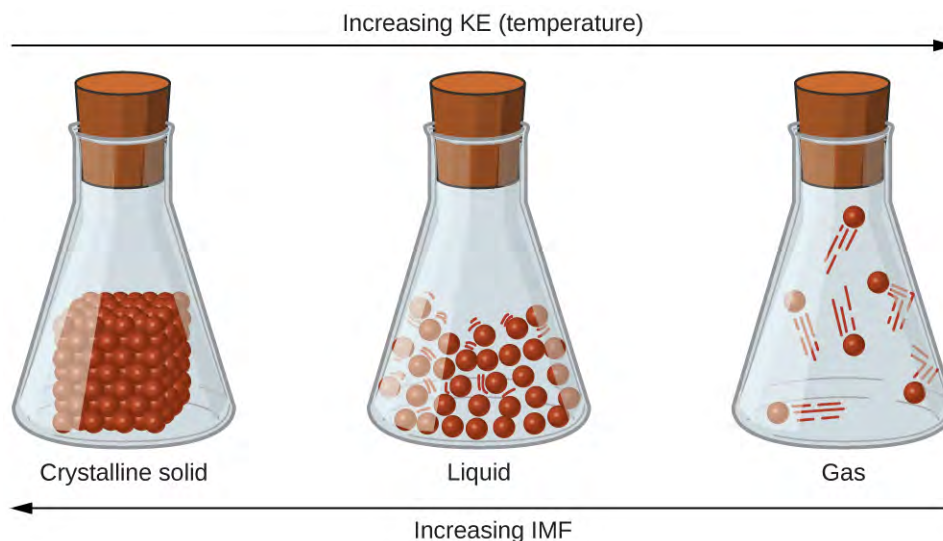

Figure 10.2 Transitions between solid, liquid, and gaseous states of a substance occur when conditions of temperature or pressure favor the associated changes in intermolecular forces. (Note: The space between particles in the gas phase is much greater than shown.)

As an example of the processes depicted in this figure, consider a sample of water. When gaseous water is cooled sufficiently, the attractions between H_2O molecules will be capable of holding them together when they come into contact with each other; the gas condenses, forming liquid H_2O . For example, liquid water forms on the outside of a cold glass as the water vapor in the air is cooled by the cold glass, as seen in **Figure 10.3**.



Figure 10.3 Condensation forms when water vapor in the air is cooled enough to form liquid water, such as (a) on the outside of a cold beverage glass or (b) in the form of fog. (credit a: modification of work by Jenny Downing; credit b: modification of work by Cory Zanker)

We can also liquefy many gases by compressing them, if the temperature is not too high. The increased pressure brings the molecules of a gas closer together, such that the attractions between the molecules become strong relative to their KE. Consequently, they form liquids. Butane, C_4H_{10} , is the fuel used in disposable lighters and is a gas at standard temperature and pressure. Inside the lighter's fuel compartment, the butane is compressed to a pressure that results in its condensation to the liquid state, as shown in **Figure 10.4**.



Figure 10.4 Gaseous butane is compressed within the storage compartment of a disposable lighter, resulting in its condensation to the liquid state. (credit: modification of work by "Sam-Cat"/Flickr)

Finally, if the temperature of a liquid becomes sufficiently low, or the pressure on the liquid becomes sufficiently high, the molecules of the liquid no longer have enough KE to overcome the IMF between them, and a solid forms. A more thorough discussion of these and other changes of state, or phase transitions, is provided in a later module of this chapter.

Link to Learning



Access this **interactive simulation** (<http://openstaxcollege.org/l/16phetvisual>) on states of matter, phase transitions, and intermolecular forces. This simulation is useful for visualizing concepts introduced throughout this chapter.

Forces between Molecules

Under appropriate conditions, the attractions between all gas molecules will cause them to form liquids or solids. This is due to intermolecular forces, not *intramolecular* forces. *Intramolecular* forces are those *within* the molecule that keep the molecule together, for example, the bonds between the atoms. *Intermolecular* forces are the attractions *between* molecules, which determine many of the physical properties of a substance. **Figure 10.5** illustrates these different molecular forces. The strengths of these attractive forces vary widely, though usually the IMFs between small molecules are weak compared to the intramolecular forces that bond atoms together within a molecule. For example, to overcome the IMFs in one mole of liquid HCl and convert it into gaseous HCl requires only about 17 kilojoules. However, to break the covalent bonds between the hydrogen and chlorine atoms in one mole of HCl requires about 25 times more energy—430 kilojoules.

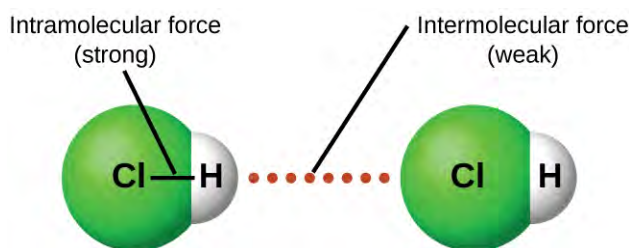

Figure 10.5 Intramolecular forces keep a molecule intact. Intermolecular forces hold multiple molecules together and determine many of a substance's properties.

All of the attractive forces between neutral atoms and molecules are known as **van der Waals forces**, although they are usually referred to more informally as intermolecular attraction. We will consider the various types of IMFs in the next three sections of this module.

Dispersion Forces

One of the three van der Waals forces is present in all condensed phases, regardless of the nature of the atoms or molecules composing the substance. This attractive force is called the London dispersion force in honor of German-born American physicist Fritz London who, in 1928, first explained it. This force is often referred to as simply the **dispersion force**. Because the electrons of an atom or molecule are in constant motion (or, alternatively, the electron's location is subject to quantum-mechanical variability), at any moment in time, an atom or molecule can develop a temporary, **instantaneous dipole** if its electrons are distributed asymmetrically. The presence of this dipole can, in turn, distort the electrons of a neighboring atom or molecule, producing an **induced dipole**. These two rapidly

fluctuating, temporary dipoles thus result in a relatively weak electrostatic attraction between the species—a so-called dispersion force like that illustrated in **Figure 10.6**.

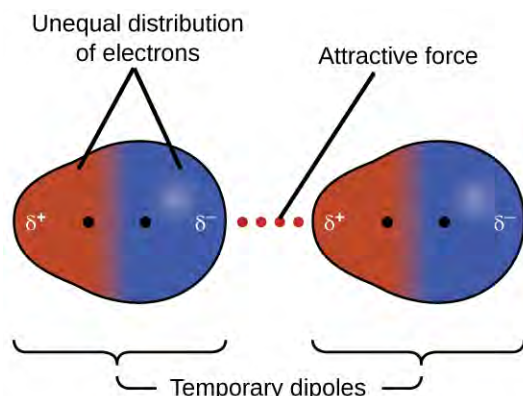

Figure 10.6 Dispersion forces result from the formation of temporary dipoles, as illustrated here for two nonpolar diatomic molecules.

Dispersion forces that develop between atoms in different molecules can attract the two molecules to each other. The forces are relatively weak, however, and become significant only when the molecules are very close. Larger and heavier atoms and molecules exhibit stronger dispersion forces than do smaller and lighter atoms and molecules. F_2 and Cl_2 are gases at room temperature (reflecting weaker attractive forces); Br_2 is a liquid, and I_2 is a solid (reflecting stronger attractive forces). Trends in observed melting and boiling points for the halogens clearly demonstrate this effect, as seen in **Table 10.1**.

Melting and Boiling Points of the Halogens

Halogen	Molar Mass	Atomic Radius	Melting Point	Boiling Point
fluorine, F_2	38 g/mol	72 pm	53 K	85 K
chlorine, Cl_2	71 g/mol	99 pm	172 K	238 K
bromine, Br_2	160 g/mol	114 pm	266 K	332 K
iodine, I_2	254 g/mol	133 pm	387 K	457 K
astatine, At_2	420 g/mol	150 pm	575 K	610 K

Table 10.1

The increase in melting and boiling points with increasing atomic/molecular size may be rationalized by considering how the strength of dispersion forces is affected by the electronic structure of the atoms or molecules in the substance. In a larger atom, the valence electrons are, on average, farther from the nuclei than in a smaller atom. Thus, they are less tightly held and can more easily form the temporary dipoles that produce the attraction. The measure of how easy or difficult it is for another electrostatic charge (for example, a nearby ion or polar molecule) to distort a molecule's charge distribution (its electron cloud) is known as **polarizability**. A molecule that has a charge cloud that is easily distorted is said to be very polarizable and will have large dispersion forces; one with a charge cloud that is difficult to distort is not very polarizable and will have small dispersion forces.

Example 10.1

London Forces and Their Effects

Order the following compounds of a group 14 element and hydrogen from lowest to highest boiling point: CH_4 , SiH_4 , GeH_4 , and SnH_4 . Explain your reasoning.

Solution

Applying the skills acquired in the chapter on chemical bonding and molecular geometry, all of these compounds are predicted to be nonpolar, so they may experience only dispersion forces: the smaller the molecule, the less polarizable and the weaker the dispersion forces; the larger the molecule, the larger the dispersion forces. The molar masses of CH_4 , SiH_4 , GeH_4 , and SnH_4 are approximately 16 g/mol, 32 g/mol, 77 g/mol, and 123 g/mol, respectively. Therefore, CH_4 is expected to have the lowest boiling point and SnH_4 the highest boiling point. The ordering from lowest to highest boiling point is expected to be $\text{CH}_4 < \text{SiH}_4 < \text{GeH}_4 < \text{SnH}_4$.

A graph of the actual boiling points of these compounds versus the period of the group 14 element shows this prediction to be correct:

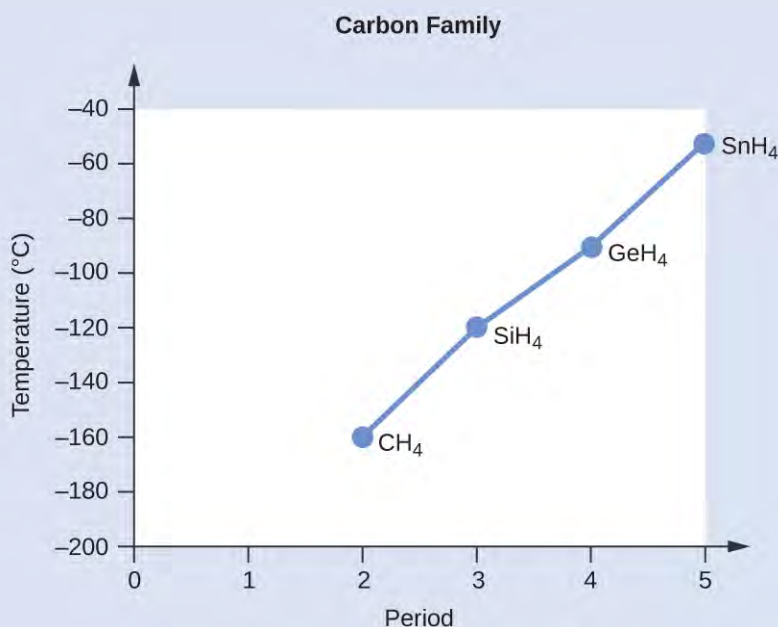

Check Your Learning

Order the following hydrocarbons from lowest to highest boiling point: C_2H_6 , C_3H_8 , and C_4H_{10} .

Answer: $\text{C}_2\text{H}_6 < \text{C}_3\text{H}_8 < \text{C}_4\text{H}_{10}$. All of these compounds are nonpolar and only have London dispersion forces: the larger the molecule, the larger the dispersion forces and the higher the boiling point. The ordering from lowest to highest boiling point is therefore $\text{C}_2\text{H}_6 < \text{C}_3\text{H}_8 < \text{C}_4\text{H}_{10}$.

The shapes of molecules also affect the magnitudes of the dispersion forces between them. For example, boiling points for the isomers *n*-pentane, isopentane, and neopentane (shown in **Figure 10.7**) are 36 °C, 27 °C, and 9.5 °C, respectively. Even though these compounds are composed of molecules with the same chemical formula, C_5H_{12} , the difference in boiling points suggests that dispersion forces in the liquid phase are different, being greatest for *n*-pentane and least for neopentane. The elongated shape of *n*-pentane provides a greater surface area available for contact between molecules, resulting in correspondingly stronger dispersion forces. The more compact shape of isopentane offers a smaller surface area available for intermolecular contact and, therefore, weaker dispersion forces. Neopentane molecules are the most compact of the three, offering the least available surface area for intermolecular

contact and, hence, the weakest dispersion forces. This behavior is analogous to the connections that may be formed between strips of VELCRO brand fasteners: the greater the area of the strip's contact, the stronger the connection.

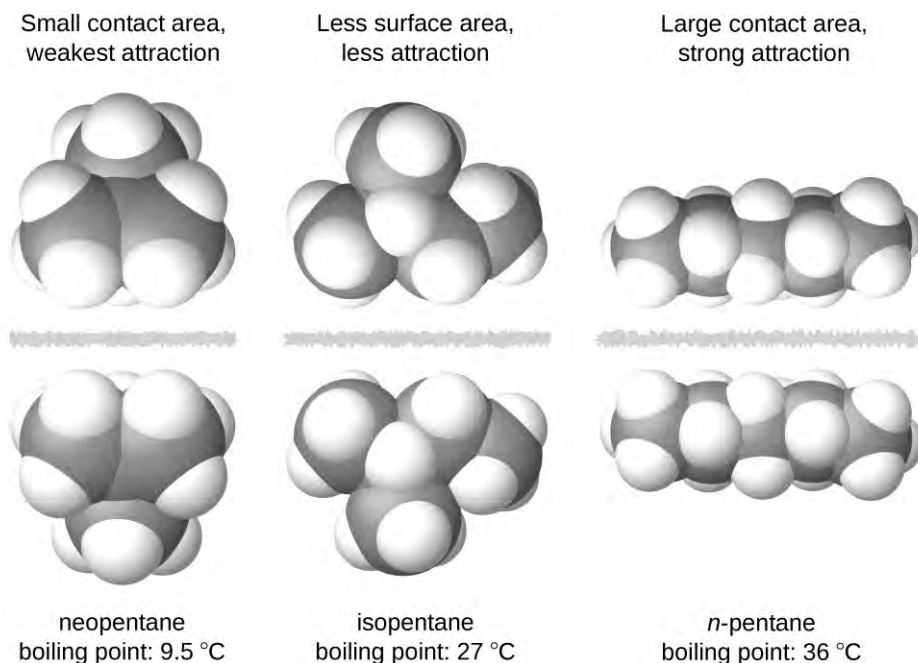

Figure 10.7 The strength of the dispersion forces increases with the contact area between molecules, as demonstrated by the boiling points of these pentane isomers.

Chemistry in Everyday Life

Geckos and Intermolecular Forces

Geckos have an amazing ability to adhere to most surfaces. They can quickly run up smooth walls and across ceilings that have no toe-holds, and they do this without having suction cups or a sticky substance on their toes. And while a gecko can lift its feet easily as it walks along a surface, if you attempt to pick it up, it sticks to the surface. How are geckos (as well as spiders and some other insects) able to do this? Although this phenomenon has been investigated for hundreds of years, scientists only recently uncovered the details of the process that allows geckos' feet to behave this way.

Geckos' toes are covered with hundreds of thousands of tiny hairs known as *setae*, with each seta, in turn, branching into hundreds of tiny, flat, triangular tips called *spatulae*. The huge numbers of spatulae on its setae provide a gecko, shown in [Figure 10.8](#), with a large total surface area for sticking to a surface. In 2000, Kellar Autumn, who leads a multi-institutional gecko research team, found that geckos adhered equally well to both polar silicon dioxide and nonpolar gallium arsenide. This proved that geckos stick to surfaces because of dispersion forces—weak intermolecular attractions arising from temporary, synchronized charge distributions between adjacent molecules. Although dispersion forces are very weak, the total attraction over millions of spatulae is large enough to support many times the gecko's weight.

In 2014, two scientists developed a model to explain how geckos can rapidly transition from “sticky” to “non-sticky.” Alex Greaney and Congcong Hu at Oregon State University described how geckos can achieve this by changing the angle between their spatulae and the surface. Geckos' feet, which are normally nonsticky, become sticky when a small shear force is applied. By curling and uncurling their toes, geckos can alternate between sticking and unsticking from a surface, and thus easily move across it. Further investigations may eventually lead to the development of better adhesives and other applications.

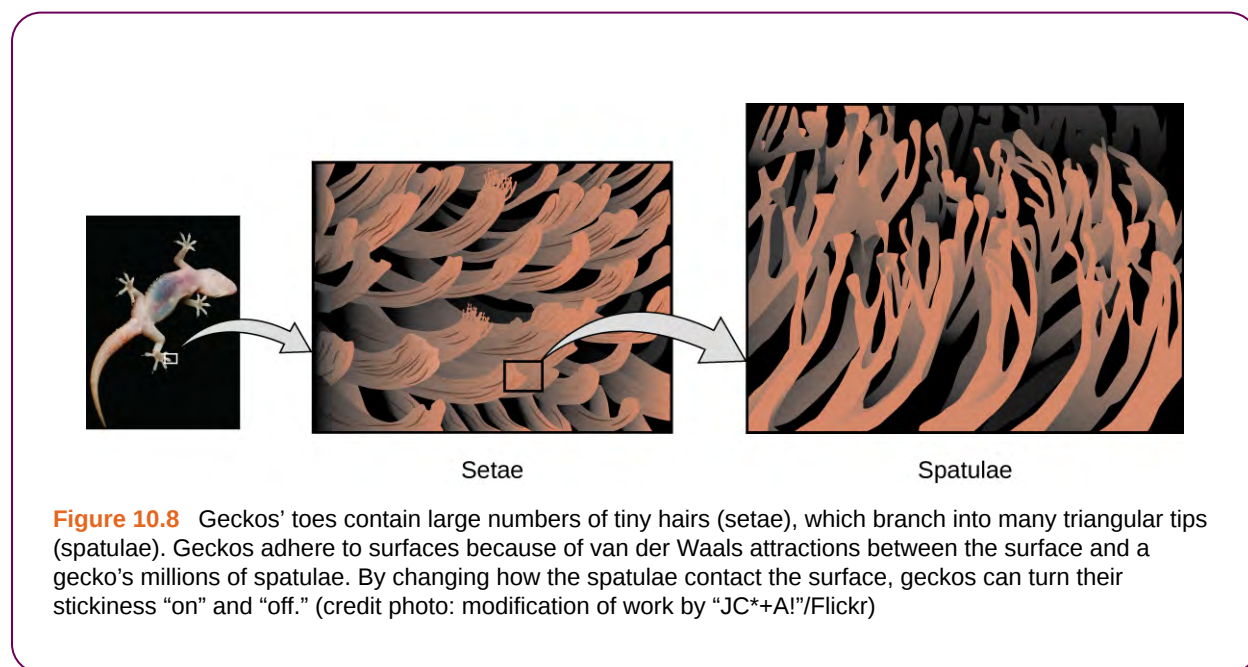

Link to Learning



Watch this [video \(http://openstaxcollege.org/l/16kellaraut\)](http://openstaxcollege.org/l/16kellaraut) to learn more about Kellar Autumn's research that determined that van der Waals forces are responsible for a gecko's ability to cling and climb.

Dipole-Dipole Attractions

Recall from the chapter on chemical bonding and molecular geometry that *polar* molecules have a partial positive charge on one side and a partial negative charge on the other side of the molecule—a separation of charge called a *dipole*. Consider a polar molecule such as hydrogen chloride, HCl. In the HCl molecule, the more electronegative Cl atom bears the partial negative charge, whereas the less electronegative H atom bears the partial positive charge. An attractive force between HCl molecules results from the attraction between the positive end of one HCl molecule and the negative end of another. This attractive force is called a **dipole-dipole attraction**—the electrostatic force between the partially positive end of one polar molecule and the partially negative end of another, as illustrated in **Figure 10.9**.

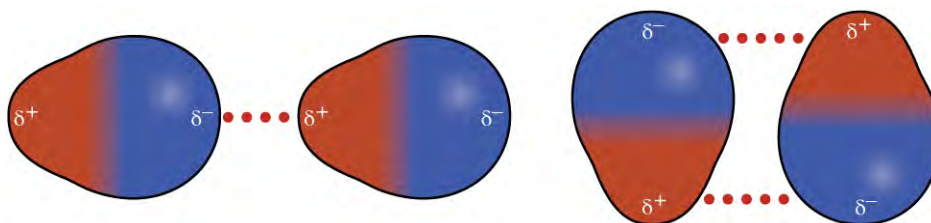

Figure 10.9 This image shows two arrangements of polar molecules, such as HCl, that allow an attraction between the partial negative end of one molecule and the partial positive end of another.

The effect of a dipole-dipole attraction is apparent when we compare the properties of HCl molecules to nonpolar F_2 molecules. Both HCl and F_2 consist of the same number of atoms and have approximately the same molecular mass. At a temperature of 150 K, molecules of both substances would have the same average KE. However, the dipole-dipole attractions between HCl molecules are sufficient to cause them to “stick together” to form a liquid, whereas the relatively weaker dispersion forces between nonpolar F_2 molecules are not, and so this substance is gaseous at this temperature. The higher normal boiling point of HCl (188 K) compared to F_2 (85 K) is a reflection of the greater strength of dipole-dipole attractions between HCl molecules, compared to the attractions between nonpolar F_2 molecules. We will often use values such as boiling or freezing points, or enthalpies of vaporization or fusion, as indicators of the relative strengths of IMFs of attraction present within different substances.

Example 10.2

Dipole-Dipole Forces and Their Effects

Predict which will have the higher boiling point: N_2 or CO. Explain your reasoning.

Solution

CO and N_2 are both diatomic molecules with masses of about 28 amu, so they experience similar London dispersion forces. Because CO is a polar molecule, it experiences dipole-dipole attractions. Because N_2 is nonpolar, its molecules cannot exhibit dipole-dipole attractions. The dipole-dipole attractions between CO molecules are comparably stronger than the dispersion forces between nonpolar N_2 molecules, so CO is expected to have the higher boiling point.

Check Your Learning

Predict which will have the higher boiling point: ICl or Br_2 . Explain your reasoning.

Answer: ICl. ICl and Br_2 have similar masses (~160 amu) and therefore experience similar London dispersion forces. ICl is polar and thus also exhibits dipole-dipole attractions; Br_2 is nonpolar and does not. The relatively stronger dipole-dipole attractions require more energy to overcome, so ICl will have the higher boiling point.

Hydrogen Bonding

Nitrosyl fluoride (ONF, molecular mass 49 amu) is a gas at room temperature. Water (H_2O , molecular mass 18 amu) is a liquid, even though it has a lower molecular mass. We clearly cannot attribute this difference between the two compounds to dispersion forces. Both molecules have about the same shape and ONF is the heavier and larger molecule. It is, therefore, expected to experience more significant dispersion forces. Additionally, we cannot attribute this difference in boiling points to differences in the dipole moments of the molecules. Both molecules are polar and exhibit comparable dipole moments. The large difference between the boiling points is due to a particularly strong dipole-dipole attraction that may occur when a molecule contains a hydrogen atom bonded to a fluorine, oxygen, or nitrogen atom (the three most electronegative elements). The very large difference in electronegativity between the H atom (2.1) and the atom to which it is bonded (4.0 for an F atom, 3.5 for an O atom, or 3.0 for a N atom), combined with the very small size of a H atom and the relatively small sizes of F, O, or N atoms, leads to *highly concentrated partial charges* with these atoms. Molecules with F-H, O-H, or N-H moieties are very strongly attracted to similar moieties in nearby molecules, a particularly strong type of dipole-dipole attraction called **hydrogen bonding**. Examples of hydrogen bonds include $HF \cdots HF$, $H_2O \cdots HOH$, and $H_3N \cdots HNH_2$, in which the hydrogen bonds are denoted by dots. **Figure 10.10** illustrates hydrogen bonding between water molecules.

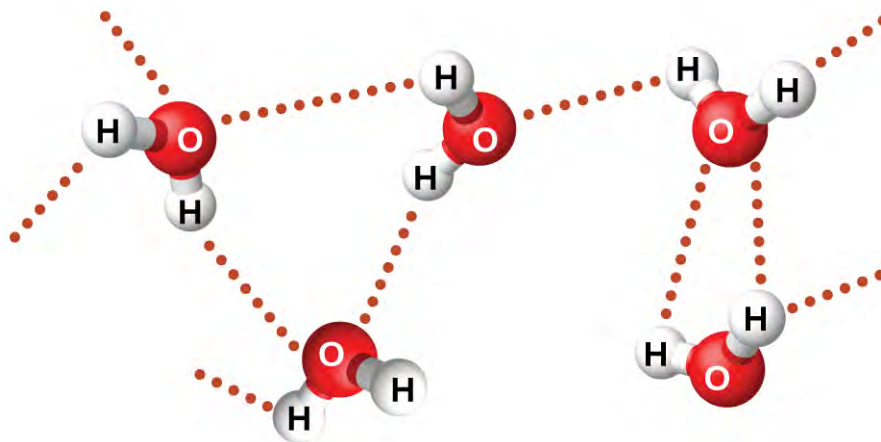

Figure 10.10 Water molecules participate in multiple hydrogen-bonding interactions with nearby water molecules.

Despite use of the word “bond,” keep in mind that hydrogen bonds are *intermolecular* attractive forces, not *intramolecular* attractive forces (covalent bonds). Hydrogen bonds are much weaker than covalent bonds, only about 5 to 10% as strong, but are generally much stronger than other dipole-dipole attractions and dispersion forces.

Hydrogen bonds have a pronounced effect on the properties of condensed phases (liquids and solids). For example, consider the trends in boiling points for the binary hydrides of group 15 (NH_3 , PH_3 , AsH_3 , and SbH_3), group 16 hydrides (H_2O , H_2S , H_2Se , and H_2Te), and group 17 hydrides (HF , HCl , HBr , and HI). The boiling points of the heaviest three hydrides for each group are plotted in **Figure 10.11**. As we progress down any of these groups, the polarities of the molecules decrease slightly, whereas the sizes of the molecules increase substantially. The effect of increasingly stronger dispersion forces dominates that of increasingly weaker dipole-dipole attractions, and the boiling points are observed to increase steadily.

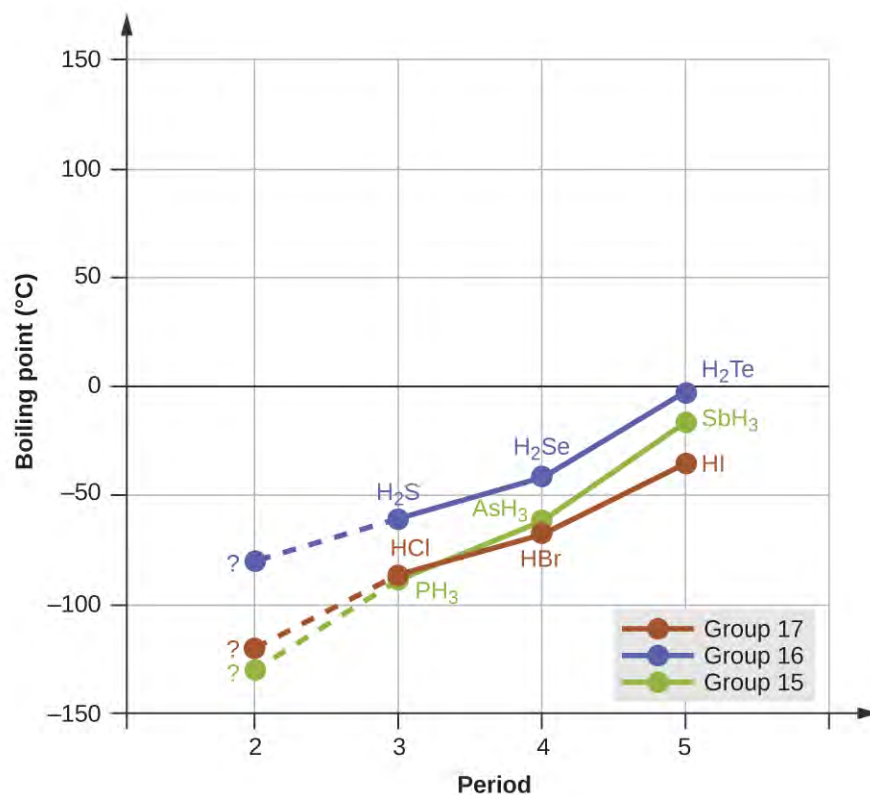

Figure 10.11 For the group 15, 16, and 17 hydrides, the boiling points for each class of compounds increase with increasing molecular mass for elements in periods 3, 4, and 5.

If we use this trend to predict the boiling points for the lightest hydride for each group, we would expect NH_3 to boil at about $-120\text{ }^\circ\text{C}$, H_2O to boil at about $-80\text{ }^\circ\text{C}$, and HF to boil at about $-110\text{ }^\circ\text{C}$. However, when we measure the boiling points for these compounds, we find that they are dramatically higher than the trends would predict, as shown in **Figure 10.12**. The stark contrast between our naïve predictions and reality provides compelling evidence for the strength of hydrogen bonding.

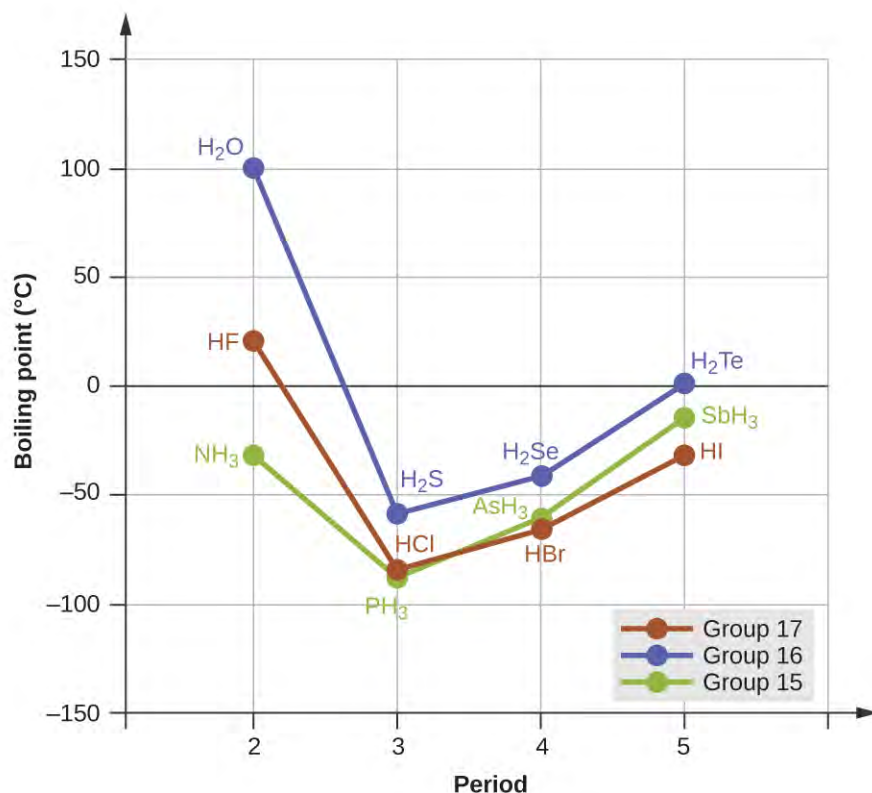

Figure 10.12 In comparison to periods 3–5, the binary hydrides of period 2 elements in groups 17, 16 and 15 (F, O and N, respectively) exhibit anomalously high boiling points due to hydrogen bonding.

Example 10.3

Effect of Hydrogen Bonding on Boiling Points

Consider the compounds dimethylether (CH_3OCH_3), ethanol ($\text{CH}_3\text{CH}_2\text{OH}$), and propane ($\text{CH}_3\text{CH}_2\text{CH}_3$). Their boiling points, not necessarily in order, are -42.1°C , -24.8°C , and 78.4°C . Match each compound with its boiling point. Explain your reasoning.

Solution

The VSEPR-predicted shapes of CH_3OCH_3 , $\text{CH}_3\text{CH}_2\text{OH}$, and $\text{CH}_3\text{CH}_2\text{CH}_3$ are similar, as are their molar masses (46 g/mol, 46 g/mol, and 44 g/mol, respectively), so they will exhibit similar dispersion forces. Since $\text{CH}_3\text{CH}_2\text{CH}_3$ is nonpolar, it may exhibit *only* dispersion forces. Because CH_3OCH_3 is polar, it will also experience dipole-dipole attractions. Finally, $\text{CH}_3\text{CH}_2\text{OH}$ has an $-\text{OH}$ group, and so it will experience the uniquely strong dipole-dipole attraction known as hydrogen bonding. So the ordering in terms of strength of IMFs, and thus boiling points, is $\text{CH}_3\text{CH}_2\text{CH}_3 < \text{CH}_3\text{OCH}_3 < \text{CH}_3\text{CH}_2\text{OH}$. The boiling point of propane is -42.1°C , the boiling point of dimethylether is -24.8°C , and the boiling point of ethanol is 78.5°C .

Check Your Learning

Ethane (CH_3CH_3) has a melting point of -183°C and a boiling point of -89°C . Predict the melting and boiling points for methylamine (CH_3NH_2). Explain your reasoning.

Answer: The melting point and boiling point for methylamine are predicted to be significantly greater than those of ethane. CH_3CH_3 and CH_3NH_2 are similar in size and mass, but methylamine possesses an $-\text{NH}$ group and therefore may exhibit hydrogen bonding. This greatly increases its IMFs, and therefore its melting

and boiling points. It is difficult to predict values, but the known values are a melting point of $-93\text{ }^{\circ}\text{C}$ and a boiling point of $-6\text{ }^{\circ}\text{C}$.

How Sciences Interconnect

Hydrogen Bonding and DNA

Deoxyribonucleic acid (DNA) is found in every living organism and contains the genetic information that determines the organism's characteristics, provides the blueprint for making the proteins necessary for life, and serves as a template to pass this information on to the organism's offspring. A DNA molecule consists of two (anti-)parallel chains of repeating nucleotides, which form its well-known double helical structure, as shown in **Figure 10.13**.

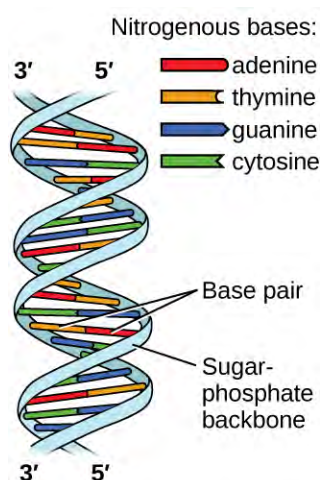

Figure 10.13 Two separate DNA molecules form a double-stranded helix in which the molecules are held together via hydrogen bonding. (credit: modification of work by Jerome Walker, Dennis Myts)

Each nucleotide contains a (deoxyribose) sugar bound to a phosphate group on one side, and one of four nitrogenous bases on the other. Two of the bases, cytosine (C) and thymine (T), are single-ringed structures known as pyrimidines. The other two, adenine (A) and guanine (G), are double-ringed structures called purines. These bases form complementary base pairs consisting of one purine and one pyrimidine, with adenine pairing with thymine, and cytosine with guanine. Each base pair is held together by hydrogen bonding. A and T share two hydrogen bonds, C and G share three, and both pairings have a similar shape and structure

Figure 10.14.

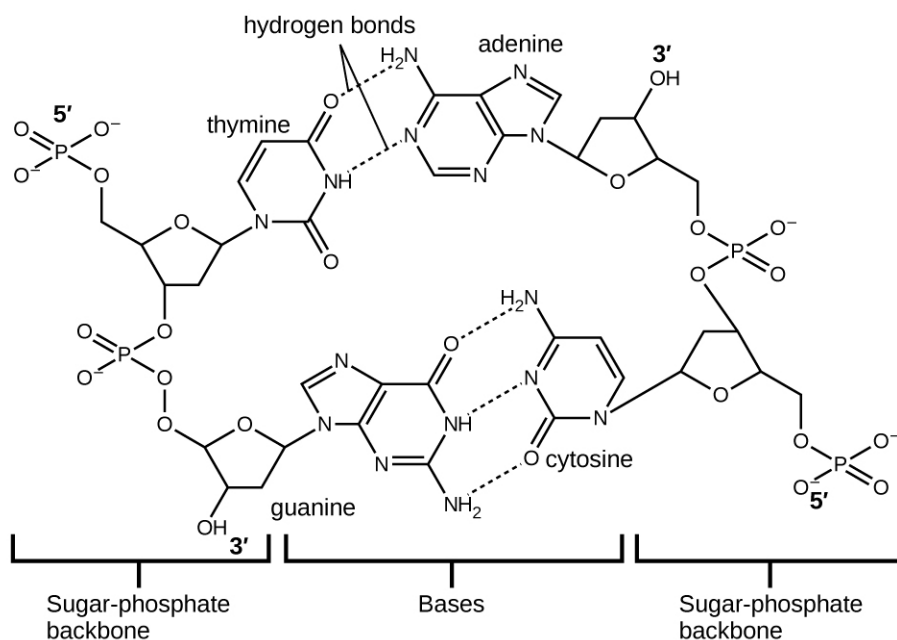

Figure 10.14 The geometries of the base molecules result in maximum hydrogen bonding between adenine and thymine (AT) and between guanine and cytosine (GC), so-called “complementary base pairs.”

The cumulative effect of millions of hydrogen bonds effectively holds the two strands of DNA together. Importantly, the two strands of DNA can relatively easily “unzip” down the middle since hydrogen bonds are relatively weak compared to the covalent bonds that hold the atoms of the individual DNA molecules together. This allows both strands to function as a template for replication.

10.2 Properties of Liquids

By the end of this section, you will be able to:

- Distinguish between adhesive and cohesive forces
- Define viscosity, surface tension, and capillary rise
- Describe the roles of intermolecular attractive forces in each of these properties/phenomena

When you pour a glass of water, or fill a car with gasoline, you observe that water and gasoline flow freely. But when you pour syrup on pancakes or add oil to a car engine, you note that syrup and motor oil do not flow as readily. The **viscosity** of a liquid is a measure of its resistance to flow. Water, gasoline, and other liquids that flow freely have a low viscosity. Honey, syrup, motor oil, and other liquids that do not flow freely, like those shown in **Figure 10.15**, have higher viscosities. We can measure viscosity by measuring the rate at which a metal ball falls through a liquid (the ball falls more slowly through a more viscous liquid) or by measuring the rate at which a liquid flows through a narrow tube (more viscous liquids flow more slowly).

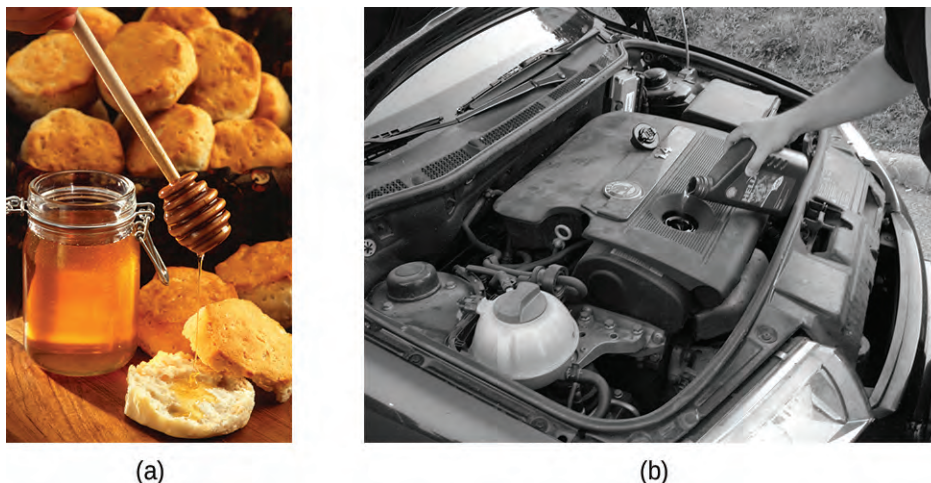

Figure 10.15 (a) Honey and (b) motor oil are examples of liquids with high viscosities; they flow slowly. (credit a: modification of work by Scott Bauer; credit b: modification of work by David Nagy)

The IMFs between the molecules of a liquid, the size and shape of the molecules, and the temperature determine how easily a liquid flows. As **Table 10.2** shows, the more structurally complex are the molecules in a liquid and the stronger the IMFs between them, the more difficult it is for them to move past each other and the greater is the viscosity of the liquid. As the temperature increases, the molecules move more rapidly and their kinetic energies are better able to overcome the forces that hold them together; thus, the viscosity of the liquid decreases.

Viscosities of Common Substances at 25 °C

Substance	Formula	Viscosity (mPa·s)
water	H ₂ O	0.890
mercury	Hg	1.526
ethanol	C ₂ H ₅ OH	1.074
octane	C ₈ H ₁₈	0.508
ethylene glycol	CH ₂ (OH)CH ₂ (OH)	16.1
honey	variable	~2,000–10,000
motor oil	variable	~50–500

Table 10.2

The various IMFs between identical molecules of a substance are examples of **cohesive forces**. The molecules within a liquid are surrounded by other molecules and are attracted equally in all directions by the cohesive forces within the liquid. However, the molecules on the surface of a liquid are attracted only by about one-half as many molecules. Because of the unbalanced molecular attractions on the surface molecules, liquids contract to form a shape that minimizes the number of molecules on the surface—that is, the shape with the minimum surface area. A small drop of liquid tends to assume a spherical shape, as shown in **Figure 10.16**, because in a sphere, the ratio of surface area to volume is at a minimum. Larger drops are more greatly affected by gravity, air resistance, surface interactions, and so on, and as a result, are less spherical.

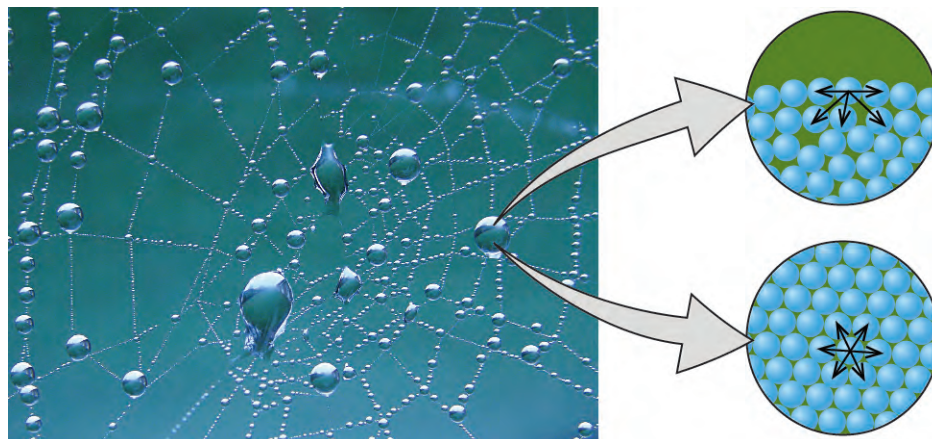

Figure 10.16 Attractive forces result in a spherical water drop that minimizes surface area; cohesive forces hold the sphere together; adhesive forces keep the drop attached to the web. (credit photo: modification of work by “OliBac”/Flickr)

Surface tension is defined as the energy required to increase the surface area of a liquid, or the force required to increase the length of a liquid surface by a given amount. This property results from the cohesive forces between molecules at the surface of a liquid, and it causes the surface of a liquid to behave like a stretched rubber membrane. Surface tensions of several liquids are presented in **Table 10.3**. Among common liquids, water exhibits a distinctly high surface tension due to strong hydrogen bonding between its molecules. As a result of this high surface tension, the surface of water represents a relatively “tough skin” that can withstand considerable force without breaking. A steel needle carefully placed on water will float. Some insects, like the one shown in **Figure 10.17**, even though they are denser than water, move on its surface because they are supported by the surface tension.

Surface Tensions of Common Substances at 25 °C

Substance	Formula	Surface Tension (mN/m)
water	H ₂ O	71.99
mercury	Hg	458.48
ethanol	C ₂ H ₅ OH	21.97
octane	C ₈ H ₁₈	21.14
ethylene glycol	CH ₂ (OH)CH ₂ (OH)	47.99

Table 10.3

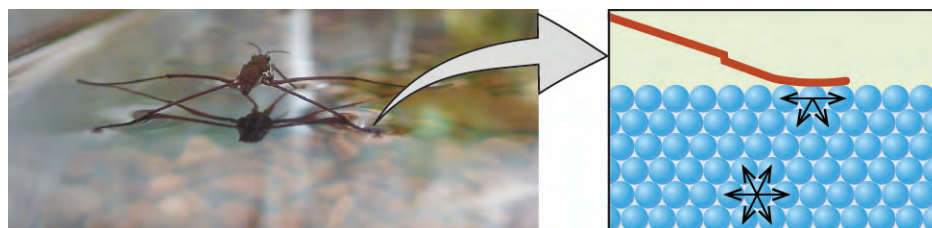

Figure 10.17 Surface tension (right) prevents this insect, a “water strider,” from sinking into the water.

The IMFs of attraction between two *different* molecules are called **adhesive forces**. Consider what happens when water comes into contact with some surface. If the adhesive forces between water molecules and the molecules of the surface are weak compared to the cohesive forces between the water molecules, the water does not “wet” the surface. For example, water does not wet waxed surfaces or many plastics such as polyethylene. Water forms drops on these surfaces because the cohesive forces within the drops are greater than the adhesive forces between the water and the plastic. Water spreads out on glass because the adhesive force between water and glass is greater than the cohesive forces within the water. When water is confined in a glass tube, its meniscus (surface) has a concave shape because the water wets the glass and creeps up the side of the tube. On the other hand, the cohesive forces between mercury atoms are much greater than the adhesive forces between mercury and glass. Mercury therefore does not wet glass, and it forms a convex meniscus when confined in a tube because the cohesive forces within the mercury tend to draw it into a drop (**Figure 10.18**).

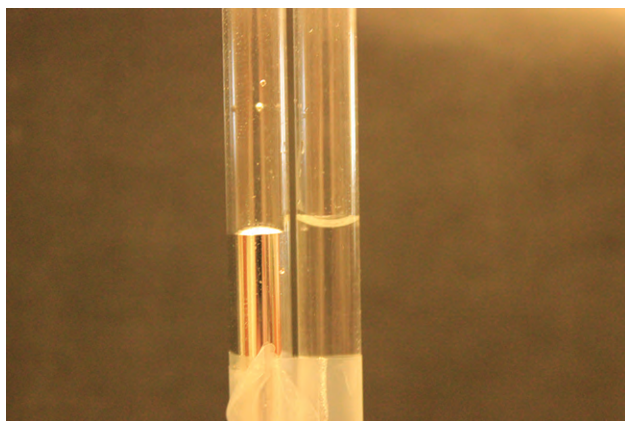

Figure 10.18 Differences in the relative strengths of cohesive and adhesive forces result in different meniscus shapes for mercury (left) and water (right) in glass tubes. (credit: Mark Ott)

If you place one end of a paper towel in spilled wine, as shown in **Figure 10.19**, the liquid wicks up the paper towel. A similar process occurs in a cloth towel when you use it to dry off after a shower. These are examples of **capillary action**—when a liquid flows within a porous material due to the attraction of the liquid molecules to the surface of the material and to other liquid molecules. The adhesive forces between the liquid and the porous material, combined with the cohesive forces within the liquid, may be strong enough to move the liquid upward against gravity.

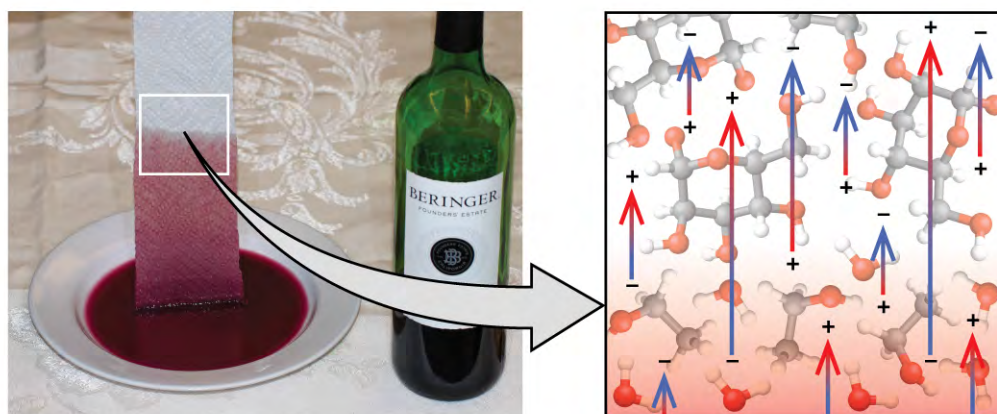

Figure 10.19 Wine wicks up a paper towel (left) because of the strong attractions of water (and ethanol) molecules to the -OH groups on the towel's cellulose fibers and the strong attractions of water molecules to other water (and ethanol) molecules (right). (credit photo: modification of work by Mark Blaser)

Towels soak up liquids like water because the fibers of a towel are made of molecules that are attracted to water molecules. Most cloth towels are made of cotton, and paper towels are generally made from paper pulp. Both consist of long molecules of cellulose that contain many -OH groups. Water molecules are attracted to these -OH groups and form hydrogen bonds with them, which draws the H_2O molecules up the cellulose molecules. The water molecules are also attracted to each other, so large amounts of water are drawn up the cellulose fibers.

Capillary action can also occur when one end of a small diameter tube is immersed in a liquid, as illustrated in **Figure 10.20**. If the liquid molecules are strongly attracted to the tube molecules, the liquid creeps up the inside of the tube until the weight of the liquid and the adhesive forces are in balance. The smaller the diameter of the tube is, the higher the liquid climbs. It is partly by capillary action occurring in plant cells called xylem that water and dissolved nutrients are brought from the soil up through the roots and into a plant. Capillary action is the basis for thin layer chromatography, a laboratory technique commonly used to separate small quantities of mixtures. You depend on a constant supply of tears to keep your eyes lubricated and on capillary action to pump tear fluid away.

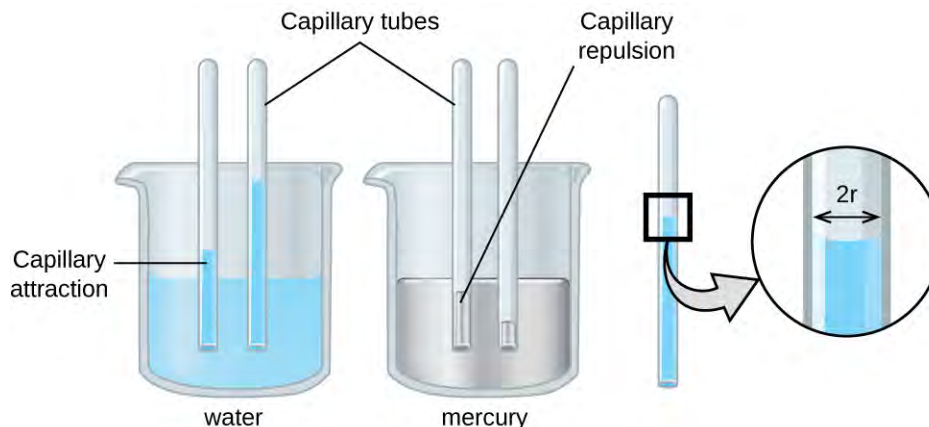

Figure 10.20 Depending upon the relative strengths of adhesive and cohesive forces, a liquid may rise (such as water) or fall (such as mercury) in a glass capillary tube. The extent of the rise (or fall) is directly proportional to the surface tension of the liquid and inversely proportional to the density of the liquid and the radius of the tube.

The height to which a liquid will rise in a capillary tube is determined by several factors as shown in the following equation:

$$h = \frac{2T \cos \theta}{r\rho g}$$

In this equation, h is the height of the liquid inside the capillary tube relative to the surface of the liquid outside the tube, T is the surface tension of the liquid, θ is the contact angle between the liquid and the tube, r is the radius of the tube, ρ is the density of the liquid, and g is the acceleration due to gravity, 9.8 m/s^2 . When the tube is made of a material to which the liquid molecules are strongly attracted, they will spread out completely on the surface, which corresponds to a contact angle of 0° . This is the situation for water rising in a glass tube.

Example 10.4

Capillary Rise

At 25°C , how high will water rise in a glass capillary tube with an inner diameter of 0.25 mm ?

For water, $T = 71.99 \text{ mN/m}$ and $\rho = 1.0 \text{ g/cm}^3$.

Solution

The liquid will rise to a height h given by: $h = \frac{2T \cos \theta}{r\rho g}$

The Newton is defined as a kg m/s^2 , and so the provided surface tension is equivalent to 0.07199 kg/s^2 . The provided density must be converted into units that will cancel appropriately: $\rho = 1000 \text{ kg/m}^3$. The diameter of the tube in meters is 0.00025 m , so the radius is 0.000125 m . For a glass tube immersed in water, the contact angle is $\theta = 0^\circ$, so $\cos \theta = 1$. Finally, acceleration due to gravity on the earth is $g = 9.8 \text{ m/s}^2$. Substituting these values into the equation, and cancelling units, we have:

$$h = \frac{2(0.07199 \text{ kg/s}^2)}{(0.000125 \text{ m})(1000 \text{ kg/m}^3)(9.8 \text{ m/s}^2)} = 0.12 \text{ m} = 12 \text{ cm}$$

Check Your Learning

Water rises in a glass capillary tube to a height of 8.4 cm . What is the diameter of the capillary tube?

Answer: diameter = 0.36 mm

Chemistry in Everyday Life

Biomedical Applications of Capillary Action

Many medical tests require drawing a small amount of blood, for example to determine the amount of glucose in someone with diabetes or the hematocrit level in an athlete. This procedure can be easily done because of capillary action, the ability of a liquid to flow up a small tube against gravity, as shown in **Figure 10.21**. When your finger is pricked, a drop of blood forms and holds together due to surface tension—the unbalanced intermolecular attractions at the surface of the drop. Then, when the open end of a narrow-diameter glass tube touches the drop of blood, the adhesive forces between the molecules in the blood and those at the glass surface draw the blood up the tube. How far the blood goes up the tube depends on the diameter of the tube (and the type of fluid). A small tube has a relatively large surface area for a given volume of blood, which results in larger (relative) attractive forces, allowing the blood to be drawn farther up the tube. The liquid itself is held together by its own cohesive forces. When the weight of the liquid in the tube generates a downward force equal to the upward force associated with capillary action, the liquid stops rising.



Figure 10.21 Blood is collected for medical analysis by capillary action, which draws blood into a small diameter glass tube. (credit: modification of work by Centers for Disease Control and Prevention)

10.3 Phase Transitions

By the end of this section, you will be able to:

- Define phase transitions and phase transition temperatures
- Explain the relation between phase transition temperatures and intermolecular attractive forces
- Describe the processes represented by typical heating and cooling curves, and compute heat flows and enthalpy changes accompanying these processes

We witness and utilize changes of physical state, or phase transitions, in a great number of ways. As one example of global significance, consider the evaporation, condensation, freezing, and melting of water. These changes of state are essential aspects of our earth's water cycle as well as many other natural phenomena and technological processes of central importance to our lives. In this module, the essential aspects of phase transitions are explored.

Vaporization and Condensation

When a liquid vaporizes in a closed container, gas molecules cannot escape. As these gas phase molecules move randomly about, they will occasionally collide with the surface of the condensed phase, and in some cases, these collisions will result in the molecules re-entering the condensed phase. The change from the gas phase to the liquid is called **condensation**. When the rate of condensation becomes equal to the rate of **vaporization**, neither the amount of the liquid nor the amount of the vapor in the container changes. The vapor in the container is then said to be *in equilibrium* with the liquid. Keep in mind that this is not a static situation, as molecules are continually exchanged between the condensed and gaseous phases. Such is an example of a **dynamic equilibrium**, the status of a system in

which reciprocal processes (for example, vaporization and condensation) occur at equal rates. The pressure exerted by the vapor in equilibrium with a liquid in a closed container at a given temperature is called the liquid's **vapor pressure** (or equilibrium vapor pressure). The area of the surface of the liquid in contact with a vapor and the size of the vessel have no effect on the vapor pressure, although they do affect the time required for the equilibrium to be reached. We can measure the vapor pressure of a liquid by placing a sample in a closed container, like that illustrated in **Figure 10.22**, and using a manometer to measure the increase in pressure that is due to the vapor in equilibrium with the condensed phase.

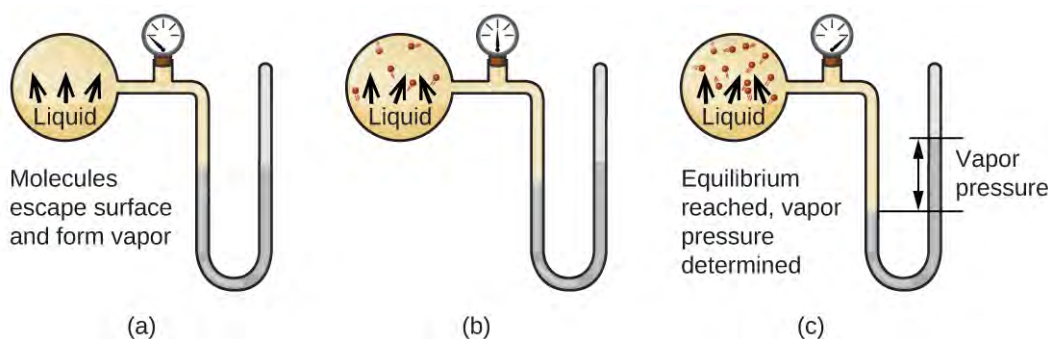

Figure 10.22 In a closed container, dynamic equilibrium is reached when (a) the rate of molecules escaping from the liquid to become the gas (b) increases and eventually (c) equals the rate of gas molecules entering the liquid. When this equilibrium is reached, the vapor pressure of the gas is constant, although the vaporization and condensation processes continue.

The chemical identities of the molecules in a liquid determine the types (and strengths) of intermolecular attractions possible; consequently, different substances will exhibit different equilibrium vapor pressures. Relatively strong intermolecular attractive forces will serve to impede vaporization as well as favoring “recapture” of gas-phase molecules when they collide with the liquid surface, resulting in a relatively low vapor pressure. Weak intermolecular attractions present less of a barrier to vaporization, and a reduced likelihood of gas recapture, yielding relatively high vapor pressures. The following example illustrates this dependence of vapor pressure on intermolecular attractive forces.

Example 10.5

Explaining Vapor Pressure in Terms of IMFs

Given the shown structural formulas for these four compounds, explain their relative vapor pressures in terms of types and extents of IMFs:

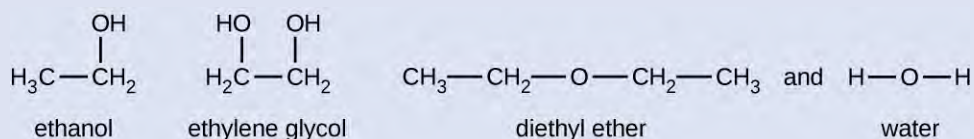

Solution

Diethyl ether has a very small dipole and most of its intermolecular attractions are London forces. Although this molecule is the largest of the four under consideration, its IMFs are the weakest and, as a result, its molecules most readily escape from the liquid. It also has the highest vapor pressure. Due to its smaller size, ethanol exhibits weaker dispersion forces than diethyl ether. However, ethanol is capable of hydrogen bonding and, therefore, exhibits stronger overall IMFs, which means that fewer molecules escape from the liquid at any given temperature, and so ethanol has a lower vapor pressure than diethyl ether. Water is much smaller than either of the previous substances and exhibits weaker dispersion forces, but its extensive

hydrogen bonding provides stronger intermolecular attractions, fewer molecules escaping the liquid, and a lower vapor pressure than for either diethyl ether or ethanol. Ethylene glycol has two $-OH$ groups, so, like water, it exhibits extensive hydrogen bonding. It is much larger than water and thus experiences larger London forces. Its overall IMFs are the largest of these four substances, which means its vaporization rate will be the slowest and, consequently, its vapor pressure the lowest.

Check Your Learning

At 20 °C, the vapor pressures of several alcohols are given in this table. Explain these vapor pressures in terms of types and extents of IMFs for these alcohols:

Compound	methanol CH_3OH	ethanol C_2H_5OH	propanol C_3H_7OH	butanol C_4H_9OH
Vapor Pressure at 25 °C	11.9 kPa	5.95 kPa	2.67 kPa	0.56 kPa

Answer: All these compounds exhibit hydrogen bonding; these strong IMFs are difficult for the molecules to overcome, so the vapor pressures are relatively low. As the size of molecule increases from methanol to butanol, dispersion forces increase, which means that the vapor pressures decrease as observed:

$$P_{\text{methanol}} > P_{\text{ethanol}} > P_{\text{propanol}} > P_{\text{butanol}}$$

As temperature increases, the vapor pressure of a liquid also increases due to the increased average KE of its molecules. Recall that at any given temperature, the molecules of a substance experience a range of kinetic energies, with a certain fraction of molecules having a sufficient energy to overcome IMF and escape the liquid (vaporize). At a higher temperature, a greater fraction of molecules have enough energy to escape from the liquid, as shown in **Figure 10.23**. The escape of more molecules per unit of time and the greater average speed of the molecules that escape both contribute to the higher vapor pressure.

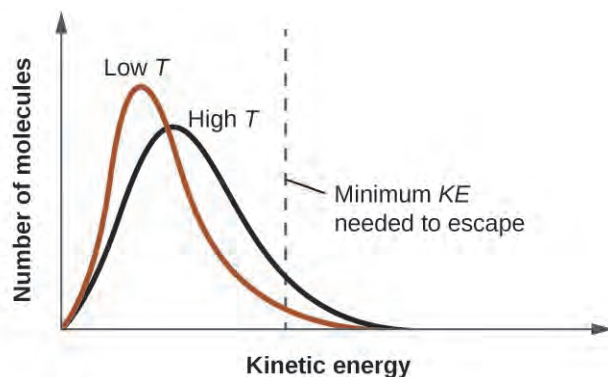

Figure 10.23 Temperature affects the distribution of kinetic energies for the molecules in a liquid. At the higher temperature, more molecules have the necessary kinetic energy, KE, to escape from the liquid into the gas phase.

Boiling Points

When the vapor pressure increases enough to equal the external atmospheric pressure, the liquid reaches its boiling point. The **boiling point** of a liquid is the temperature at which its equilibrium vapor pressure is equal to the pressure exerted on the liquid by its gaseous surroundings. For liquids in open containers, this pressure is that due to the earth's atmosphere. The **normal boiling point** of a liquid is defined as its boiling point when surrounding pressure is equal to 1 atm (101.3 kPa). **Figure 10.24** shows the variation in vapor pressure with temperature for several different

substances. Considering the definition of boiling point, these curves may be seen as depicting the dependence of a liquid's boiling point on surrounding pressure.

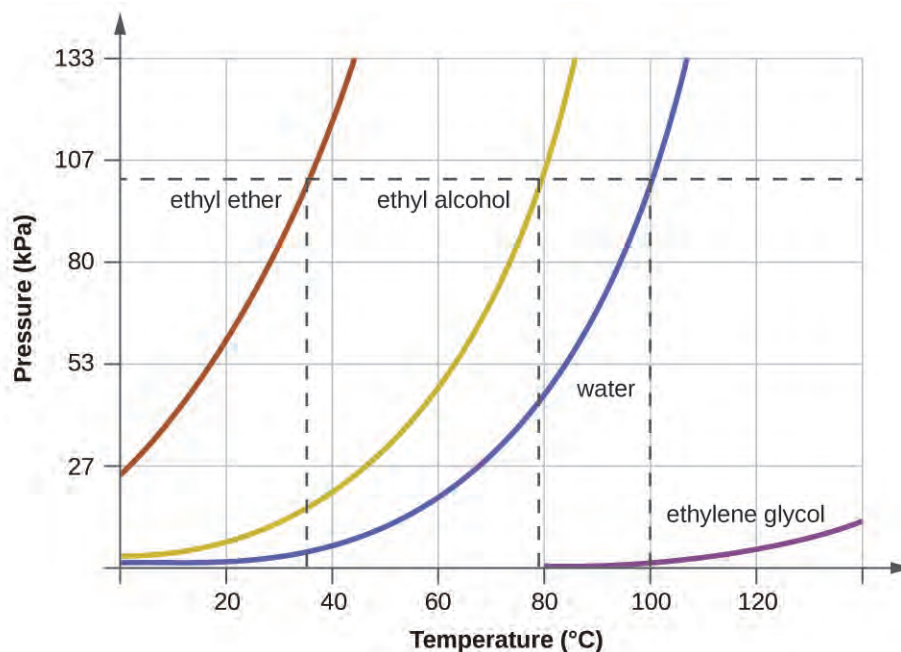

Figure 10.24 The boiling points of liquids are the temperatures at which their equilibrium vapor pressures equal the pressure of the surrounding atmosphere. Normal boiling points are those corresponding to a pressure of 1 atm (101.3 kPa.)

Example 10.6

A Boiling Point at Reduced Pressure

A typical atmospheric pressure in Leadville, Colorado (elevation 10,200 feet) is 68 kPa. Use the graph in **Figure 10.24** to determine the boiling point of water at this elevation.

Solution

The graph of the vapor pressure of water versus temperature in **Figure 10.24** indicates that the vapor pressure of water is 68 kPa at about 90 °C. Thus, at about 90 °C, the vapor pressure of water will equal the atmospheric pressure in Leadville, and water will boil.

Check Your Learning

The boiling point of ethyl ether was measured to be 10 °C at a base camp on the slopes of Mount Everest. Use **Figure 10.24** to determine the approximate atmospheric pressure at the camp.

Answer: Approximately 40 kPa (0.4 atm)

The quantitative relation between a substance's vapor pressure and its temperature is described by the **Clausius-Clapeyron equation**:

$$P = Ae^{-\Delta H_{\text{vap}}/RT}$$

where ΔH_{vap} is the enthalpy of vaporization for the liquid, R is the gas constant, and $\ln A$ is a constant whose value depends on the chemical identity of the substance. This equation is often rearranged into logarithmic form to yield the linear equation:

$$\ln P = -\frac{\Delta H_{\text{vap}}}{RT} + \ln A$$

This linear equation may be expressed in a two-point format that is convenient for use in various computations, as demonstrated in the example exercises that follow. If at temperature T_1 , the vapor pressure is P_1 , and at temperature T_2 , the vapor pressure is P_2 , the corresponding linear equations are:

$$\ln P_1 = -\frac{\Delta H_{\text{vap}}}{RT_1} + \ln A \quad \text{and} \quad \ln P_2 = -\frac{\Delta H_{\text{vap}}}{RT_2} + \ln A$$

Since the constant, $\ln A$, is the same, these two equations may be rearranged to isolate $\ln A$ and then set them equal to one another:

$$\ln P_1 + \frac{\Delta H_{\text{vap}}}{RT_1} = \ln P_2 + \frac{\Delta H_{\text{vap}}}{RT_2}$$

which can be combined into:

$$\ln\left(\frac{P_2}{P_1}\right) = \frac{\Delta H_{\text{vap}}}{R}\left(\frac{1}{T_1} - \frac{1}{T_2}\right)$$

Example 10.7

Estimating Enthalpy of Vaporization

Isooctane (2,2,4-trimethylpentane) has an octane rating of 100. It is used as one of the standards for the octane-rating system for gasoline. At 34.0 °C, the vapor pressure of isooctane is 10.0 kPa, and at 98.8 °C, its vapor pressure is 100.0 kPa. Use this information to estimate the enthalpy of vaporization for isooctane.

Solution

The enthalpy of vaporization, ΔH_{vap} , can be determined by using the Clausius-Clapeyron equation:

$$\ln\left(\frac{P_2}{P_1}\right) = \frac{\Delta H_{\text{vap}}}{R}\left(\frac{1}{T_1} - \frac{1}{T_2}\right)$$

Since we have two vapor pressure-temperature values ($T_1 = 34.0\text{ °C} = 307.2\text{ K}$, $P_1 = 10.0\text{ kPa}$ and $T_2 = 98.8\text{ °C} = 372.0\text{ K}$, $P_2 = 100\text{ kPa}$), we can substitute them into this equation and solve for ΔH_{vap} . Rearranging the Clausius-Clapeyron equation and solving for ΔH_{vap} yields:

$$\Delta H_{\text{vap}} = \frac{R \cdot \ln\left(\frac{P_2}{P_1}\right)}{\left(\frac{1}{T_1} - \frac{1}{T_2}\right)} = \frac{(8.3145\text{ J/mol}\cdot\text{K}) \cdot \ln\left(\frac{100\text{ kPa}}{10.0\text{ kPa}}\right)}{\left(\frac{1}{307.2\text{ K}} - \frac{1}{372.0\text{ K}}\right)} = 33,800\text{ J/mol} = 33.8\text{ kJ/mol}$$

Note that the pressure can be in any units, so long as they agree for both P values, but the temperature must be in kelvin for the Clausius-Clapeyron equation to be valid.

Check Your Learning

At 20.0 °C, the vapor pressure of ethanol is 5.95 kPa, and at 63.5 °C, its vapor pressure is 53.3 kPa. Use this information to estimate the enthalpy of vaporization for ethanol.

Answer: 47,782 J/mol = 47.8 kJ/mol

Example 10.8

Estimating Temperature (or Vapor Pressure)

For benzene (C_6H_6), the normal boiling point is 80.1 °C and the enthalpy of vaporization is 30.8 kJ/mol. What is the boiling point of benzene in Denver, where atmospheric pressure = 83.4 kPa?

Solution

If the temperature and vapor pressure are known at one point, along with the enthalpy of vaporization, ΔH_{vap} , then the temperature that corresponds to a different vapor pressure (or the vapor pressure that corresponds to a different temperature) can be determined by using the Clausius-Clapeyron equation:

$$\ln\left(\frac{P_2}{P_1}\right) = \frac{\Delta H_{\text{vap}}}{R} \left(\frac{1}{T_1} - \frac{1}{T_2}\right)$$

Since the normal boiling point is the temperature at which the vapor pressure equals atmospheric pressure at sea level, we know one vapor pressure-temperature value ($T_1 = 80.1^\circ\text{C} = 353.3\text{ K}$, $P_1 = 101.3\text{ kPa}$, $\Delta H_{\text{vap}} = 30.8\text{ kJ/mol}$) and want to find the temperature (T_2) that corresponds to vapor pressure $P_2 = 83.4\text{ kPa}$. We can substitute these values into the Clausius-Clapeyron equation and then solve for T_2 . Rearranging the Clausius-Clapeyron equation and solving for T_2 yields:

$$T_2 = \left(\frac{-R \cdot \ln\left(\frac{P_2}{P_1}\right)}{\Delta H_{\text{vap}}} + \frac{1}{T_1} \right)^{-1} = \left(\frac{-(8.3145\text{ J/mol}\cdot\text{K}) \cdot \ln\left(\frac{83.4\text{ kPa}}{101.3\text{ kPa}}\right)}{30,800\text{ J/mol}} + \frac{1}{353.3\text{ K}} \right)^{-1} = 346.9\text{ K or }73.8^\circ\text{ C}$$

Check Your Learning

For acetone ($\text{CH}_3)_2\text{CO}$, the normal boiling point is 56.5°C and the enthalpy of vaporization is 31.3 kJ/mol . What is the vapor pressure of acetone at 25.0°C ?

Answer: 30.1 kPa

Enthalpy of Vaporization

Vaporization is an endothermic process. The cooling effect can be evident when you leave a swimming pool or a shower. When the water on your skin evaporates, it removes heat from your skin and causes you to feel cold. The energy change associated with the vaporization process is the enthalpy of vaporization, ΔH_{vap} . For example, the vaporization of water at standard temperature is represented by:



As described in the chapter on thermochemistry, the reverse of an endothermic process is exothermic. And so, the condensation of a gas releases heat:



Example 10.9

Using Enthalpy of Vaporization

One way our body is cooled is by evaporation of the water in sweat (**Figure 10.25**). In very hot climates, we can lose as much as 1.5 L of sweat per day. Although sweat is not pure water, we can get an approximate value of the amount of heat removed by evaporation by assuming that it is. How much heat is required to evaporate 1.5 L of water (1.5 kg) at $T = 37^\circ\text{C}$ (normal body temperature); $\Delta H_{\text{vap}} = 43.46\text{ kJ/mol}$ at 37°C .



Figure 10.25 Evaporation of sweat helps cool the body. (credit: "Kullez"/Flickr)

Solution

We start with the known volume of sweat (approximated as just water) and use the given information to convert to the amount of heat needed:

$$1.5 \text{ L} \times \frac{1000 \text{ g}}{1 \text{ L}} \times \frac{1 \text{ mol}}{18 \text{ g}} \times \frac{43.46 \text{ kJ}}{1 \text{ mol}} = 3.6 \times 10^3 \text{ kJ}$$

Thus, 3600 kJ of heat are removed by the evaporation of 1.5 L of water.

Check Your Learning

How much heat is required to evaporate 100.0 g of liquid ammonia, NH_3 , at its boiling point if its enthalpy of vaporization is 4.8 kJ/mol?

Answer: 28 kJ

Melting and Freezing

When we heat a crystalline solid, we increase the average energy of its atoms, molecules, or ions and the solid gets hotter. At some point, the added energy becomes large enough to partially overcome the forces holding the molecules or ions of the solid in their fixed positions, and the solid begins the process of transitioning to the liquid state, or **melting**. At this point, the temperature of the solid stops rising, despite the continual input of heat, and it remains constant until all of the solid is melted. Only after all of the solid has melted will continued heating increase the temperature of the liquid (**Figure 10.26**).



Figure 10.26 (a) This beaker of ice has a temperature of $-12.0\text{ }^{\circ}\text{C}$. (b) After 10 minutes the ice has absorbed enough heat from the air to warm to $0\text{ }^{\circ}\text{C}$. A small amount has melted. (c) Thirty minutes later, the ice has absorbed more heat, but its temperature is still $0\text{ }^{\circ}\text{C}$. The ice melts without changing its temperature. (d) Only after all the ice has melted does the heat absorbed cause the temperature to increase to $22.2\text{ }^{\circ}\text{C}$. (credit: modification of work by Mark Ott)

If we stop heating during melting and place the mixture of solid and liquid in a perfectly insulated container so no heat can enter or escape, the solid and liquid phases remain in equilibrium. This is almost the situation with a mixture of ice and water in a very good thermos bottle; almost no heat gets in or out, and the mixture of solid ice and liquid water remains for hours. In a mixture of solid and liquid at equilibrium, the reciprocal process of melting and **freezing** occur at equal rates, and the quantities of solid and liquid therefore remain constant. The temperature at which the solid and liquid phases of a given substance are in equilibrium is called the **melting point** of the solid or the **freezing point** of the liquid. Use of one term or the other is normally dictated by the direction of the phase transition being considered, for example, solid to liquid (melting) or liquid to solid (freezing).

The enthalpy of fusion and the melting point of a crystalline solid depend on the strength of the attractive forces between the units present in the crystal. Molecules with weak attractive forces form crystals with low melting points. Crystals consisting of particles with stronger attractive forces melt at higher temperatures.

The amount of heat required to change one mole of a substance from the solid state to the liquid state is the enthalpy of fusion, ΔH_{fus} of the substance. The enthalpy of fusion of ice is 6.0 kJ/mol at $0\text{ }^{\circ}\text{C}$. Fusion (melting) is an endothermic process:



The reciprocal process, freezing, is an exothermic process whose enthalpy change is -6.0 kJ/mol at $0\text{ }^{\circ}\text{C}$:



Sublimation and Deposition

Some solids can transition directly into the gaseous state, bypassing the liquid state, via a process known as **sublimation**. At room temperature and standard pressure, a piece of dry ice (solid CO_2) sublimates, appearing to gradually disappear without ever forming any liquid. Snow and ice sublime at temperatures below the melting point of water, a slow process that may be accelerated by winds and the reduced atmospheric pressures at high altitudes. When solid iodine is warmed, the solid sublimates and a vivid purple vapor forms (**Figure 10.27**). The reverse of sublimation is called **deposition**, a process in which gaseous substances condense directly into the solid state, bypassing the liquid state. The formation of frost is an example of deposition.

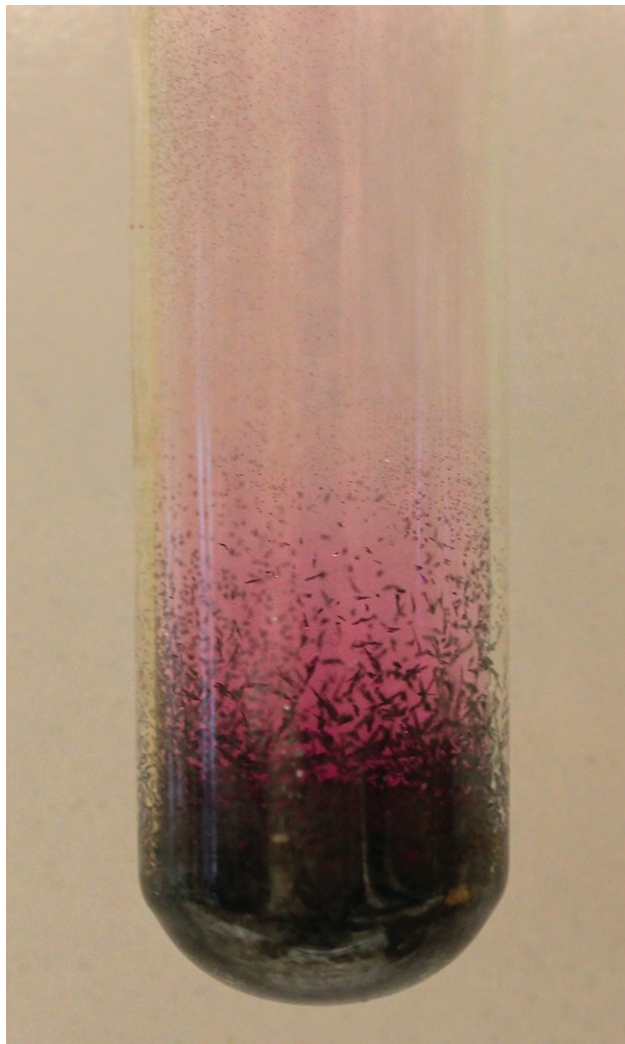

Figure 10.27 Sublimation of solid iodine in the bottom of the tube produces a purple gas that subsequently deposits as solid iodine on the colder part of the tube above. (credit: modification of work by Mark Ott)

Like vaporization, the process of sublimation requires an input of energy to overcome intermolecular attractions. The enthalpy of sublimation, ΔH_{sub} , is the energy required to convert one mole of a substance from the solid to the gaseous state. For example, the sublimation of carbon dioxide is represented by:



Likewise, the enthalpy change for the reverse process of deposition is equal in magnitude but opposite in sign to that for sublimation:



Consider the extent to which intermolecular attractions must be overcome to achieve a given phase transition. Converting a solid into a liquid requires that these attractions be only partially overcome; transition to the gaseous state requires that they be completely overcome. As a result, the enthalpy of fusion for a substance is less than its enthalpy of vaporization. This same logic can be used to derive an approximate relation between the enthalpies of all phase changes for a given substance. Though not an entirely accurate description, sublimation may be conveniently modeled as a sequential two-step process of melting followed by vaporization in order to apply Hess's Law. Viewed

in this manner, the enthalpy of sublimation for a substance may be estimated as the sum of its enthalpies of fusion and vaporization, as illustrated in **Figure 10.28**. For example:

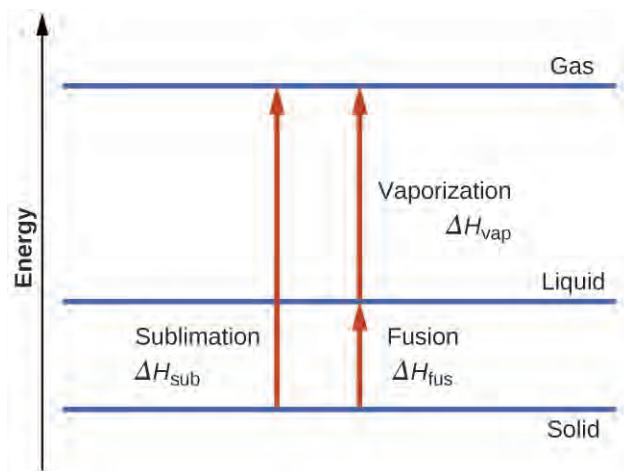
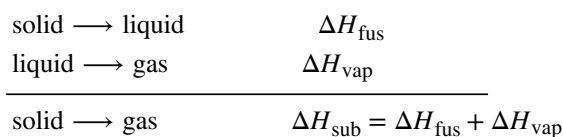

Figure 10.28 For a given substance, the sum of its enthalpy of fusion and enthalpy of vaporization is approximately equal to its enthalpy of sublimation.

Heating and Cooling Curves

In the chapter on thermochemistry, the relation between the amount of heat absorbed or related by a substance, q , and its accompanying temperature change, ΔT , was introduced:

$$q = mc\Delta T$$

where m is the mass of the substance and c is its specific heat. The relation applies to matter being heated or cooled, but not undergoing a change in state. When a substance being heated or cooled reaches a temperature corresponding to one of its phase transitions, further gain or loss of heat is a result of diminishing or enhancing intermolecular attractions, instead of increasing or decreasing molecular kinetic energies. While a substance is undergoing a change in state, its temperature remains constant. **Figure 10.29** shows a typical heating curve.

Consider the example of heating a pot of water to boiling. A stove burner will supply heat at a roughly constant rate; initially, this heat serves to increase the water's temperature. When the water reaches its boiling point, the temperature remains constant despite the continued input of heat from the stove burner. This same temperature is maintained by the water as long as it is boiling. If the burner setting is increased to provide heat at a greater rate, the water temperature does not rise, but instead the boiling becomes more vigorous (rapid). This behavior is observed for other phase transitions as well: For example, temperature remains constant while the change of state is in progress.

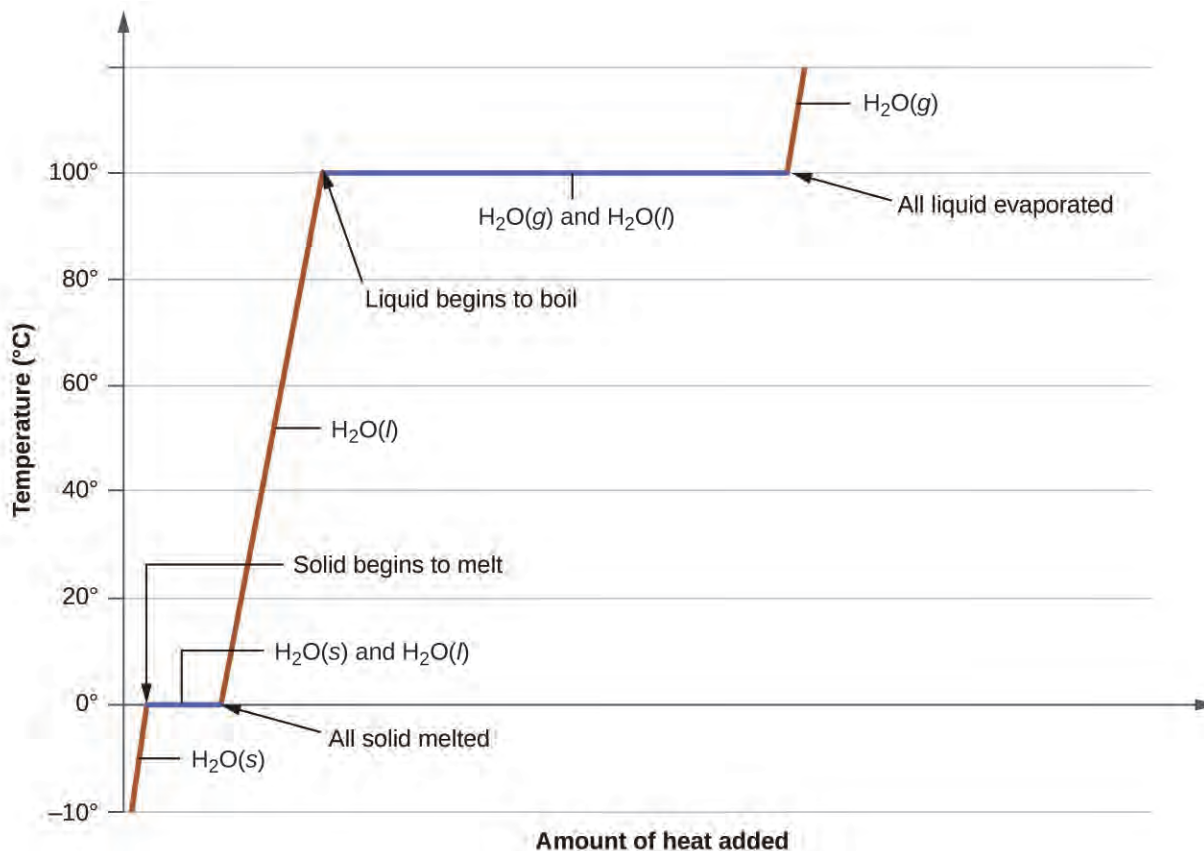

Figure 10.29 A typical heating curve for a substance depicts changes in temperature that result as the substance absorbs increasing amounts of heat. Plateaus in the curve (regions of constant temperature) are exhibited when the substance undergoes phase transitions.

Example 10.10

Total Heat Needed to Change Temperature and Phase for a Substance

How much heat is required to convert 135 g of ice at $-15\text{ }^{\circ}\text{C}$ into water vapor at $120\text{ }^{\circ}\text{C}$?

Solution

The transition described involves the following steps:

1. Heat ice from $-15\text{ }^{\circ}\text{C}$ to $0\text{ }^{\circ}\text{C}$
2. Melt ice
3. Heat water from $0\text{ }^{\circ}\text{C}$ to $100\text{ }^{\circ}\text{C}$
4. Boil water
5. Heat steam from $100\text{ }^{\circ}\text{C}$ to $120\text{ }^{\circ}\text{C}$

The heat needed to change the temperature of a given substance (with no change in phase) is: $q = m \times c \times \Delta T$ (see previous chapter on thermochemistry). The heat needed to induce a given change in phase is given by $q = n \times \Delta H$.

Using these equations with the appropriate values for specific heat of ice, water, and steam, and enthalpies of fusion and vaporization, we have:

$$\begin{aligned}
 q_{\text{total}} &= (m \cdot c \cdot \Delta T)_{\text{ice}} + n \cdot \Delta H_{\text{fus}} + (m \cdot c \cdot \Delta T)_{\text{water}} + n \cdot \Delta H_{\text{vap}} + (m \cdot c \cdot \Delta T)_{\text{steam}} \\
 &= (135 \text{ g} \cdot 2.09 \text{ J/g} \cdot ^\circ\text{C} \cdot 15^\circ\text{C}) + \left(135 \cdot \frac{1 \text{ mol}}{18.02 \text{ g}} \cdot 6.01 \text{ kJ/mol}\right) \\
 &\quad + (135 \text{ g} \cdot 4.18 \text{ J/g} \cdot ^\circ\text{C} \cdot 100^\circ\text{C}) + \left(135 \text{ g} \cdot \frac{1 \text{ mol}}{18.02 \text{ g}} \cdot 40.67 \text{ kJ/mol}\right) \\
 &\quad + (135 \text{ g} \cdot 1.84 \text{ J/g} \cdot ^\circ\text{C} \cdot 20^\circ\text{C}) \\
 &= 4230 \text{ J} + 45.0 \text{ kJ} + 56,500 \text{ J} + 305 \text{ kJ} + 4970 \text{ J}
 \end{aligned}$$

Converting the quantities in J to kJ permits them to be summed, yielding the total heat required:

$$= 4.23 \text{ kJ} + 45.0 \text{ kJ} + 56.5 \text{ kJ} + 305 \text{ kJ} + 4.97 \text{ kJ} = 416 \text{ kJ}$$

Check Your Learning

What is the total amount of heat released when 94.0 g water at 80.0 °C cools to form ice at −30.0 °C?

Answer: 40.5 kJ

10.4 Phase Diagrams

By the end of this section, you will be able to:

- Explain the construction and use of a typical phase diagram
- Use phase diagrams to identify stable phases at given temperatures and pressures, and to describe phase transitions resulting from changes in these properties
- Describe the supercritical fluid phase of matter

In the previous module, the variation of a liquid's equilibrium vapor pressure with temperature was described. Considering the definition of boiling point, plots of vapor pressure versus temperature represent how the boiling point of the liquid varies with pressure. Also described was the use of heating and cooling curves to determine a substance's melting (or freezing) point. Making such measurements over a wide range of pressures yields data that may be presented graphically as a phase diagram. A **phase diagram** combines plots of pressure versus temperature for the liquid-gas, solid-liquid, and solid-gas phase-transition equilibria of a substance. These diagrams indicate the physical states that exist under specific conditions of pressure and temperature, and also provide the pressure dependence of the phase-transition temperatures (melting points, sublimation points, boiling points). A typical phase diagram for a pure substance is shown in **Figure 10.30**.

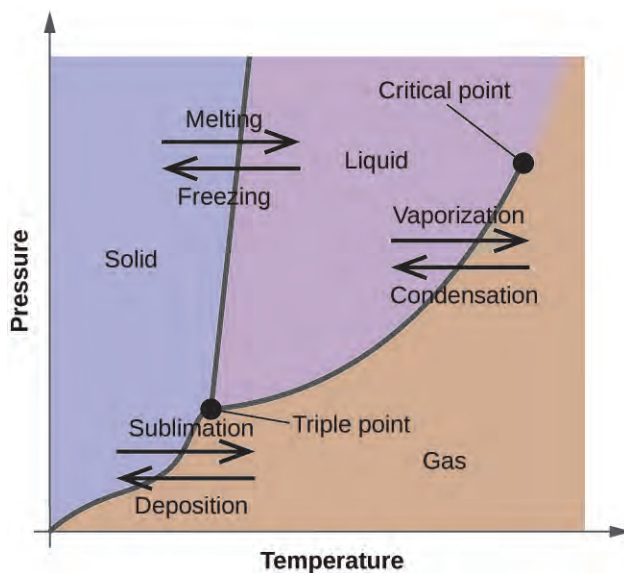

Figure 10.30 The physical state of a substance and its phase-transition temperatures are represented graphically in a phase diagram.

To illustrate the utility of these plots, consider the phase diagram for water shown in **Figure 10.31**.

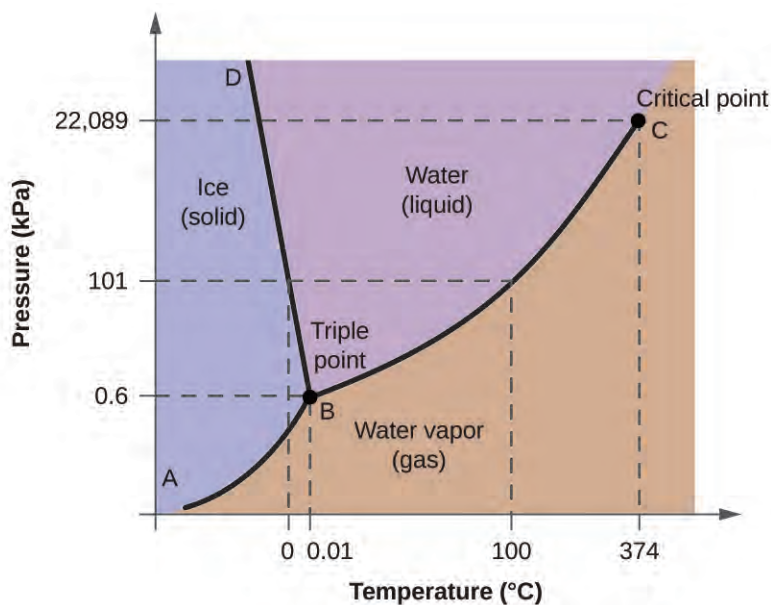

Figure 10.31 The pressure and temperature axes on this phase diagram of water are not drawn to constant scale in order to illustrate several important properties.

We can use the phase diagram to identify the physical state of a sample of water under specified conditions of pressure and temperature. For example, a pressure of 50 kPa and a temperature of $-10\text{ }^{\circ}\text{C}$ correspond to the region of the diagram labeled “ice.” Under these conditions, water exists only as a solid (ice). A pressure of 50 kPa and a temperature of $50\text{ }^{\circ}\text{C}$ correspond to the “water” region—here, water exists only as a liquid. At 25 kPa and $200\text{ }^{\circ}\text{C}$, water exists only in the gaseous state. Note that on the H_2O phase diagram, the pressure and temperature axes are not drawn to a constant scale in order to permit the illustration of several important features as described here.

The curve BC in **Figure 10.31** is the plot of vapor pressure versus temperature as described in the previous module of this chapter. This “liquid-vapor” curve separates the liquid and gaseous regions of the phase diagram and provides the boiling point for water at any pressure. For example, at 1 atm, the boiling point is 100 °C. Notice that the liquid-vapor curve terminates at a temperature of 374 °C and a pressure of 218 atm, indicating that water cannot exist as a liquid above this temperature, regardless of the pressure. The physical properties of water under these conditions are intermediate between those of its liquid and gaseous phases. This unique state of matter is called a supercritical fluid, a topic that will be described in the next section of this module.

The solid-vapor curve, labeled AB in **Figure 10.31**, indicates the temperatures and pressures at which ice and water vapor are in equilibrium. These temperature-pressure data pairs correspond to the sublimation, or deposition, points for water. If we could zoom in on the solid-gas line in **Figure 10.31**, we would see that ice has a vapor pressure of about 0.20 kPa at -10 °C. Thus, if we place a frozen sample in a vacuum with a pressure less than 0.20 kPa, ice will sublime. This is the basis for the “freeze-drying” process often used to preserve foods, such as the ice cream shown in **Figure 10.32**.



Figure 10.32 Freeze-dried foods, like this ice cream, are dehydrated by sublimation at pressures below the triple point for water. (credit: "lwao"/Flickr)

The solid-liquid curve labeled BD shows the temperatures and pressures at which ice and liquid water are in equilibrium, representing the melting/freezing points for water. Note that this curve exhibits a slight negative slope (greatly exaggerated for clarity), indicating that the melting point for water decreases slightly as pressure increases. Water is an unusual substance in this regard, as most substances exhibit an increase in melting point with increasing pressure. This behavior is partly responsible for the movement of glaciers, like the one shown in **Figure 10.33**. The bottom of a glacier experiences an immense pressure due to its weight that can melt some of the ice, forming a layer of liquid water on which the glacier may more easily slide.



Figure 10.33 The immense pressures beneath glaciers result in partial melting to produce a layer of water that provides lubrication to assist glacial movement. This satellite photograph shows the advancing edge of the Perito Moreno glacier in Argentina. (credit: NASA)

The point of intersection of all three curves is labeled B in **Figure 10.31**. At the pressure and temperature represented by this point, all three phases of water coexist in equilibrium. This temperature-pressure data pair is called the **triple point**. At pressures lower than the triple point, water cannot exist as a liquid, regardless of the temperature.

Example 10.11

Determining the State of Water

Using the phase diagram for water given in **Figure 10.31**, determine the state of water at the following temperatures and pressures:

- (a) $-10\text{ }^{\circ}\text{C}$ and 50 kPa
- (b) $25\text{ }^{\circ}\text{C}$ and 90 kPa
- (c) $50\text{ }^{\circ}\text{C}$ and 40 kPa
- (d) $80\text{ }^{\circ}\text{C}$ and 5 kPa
- (e) $-10\text{ }^{\circ}\text{C}$ and 0.3 kPa
- (f) $50\text{ }^{\circ}\text{C}$ and 0.3 kPa

Solution

Using the phase diagram for water, we can determine that the state of water at each temperature and pressure given are as follows: (a) solid; (b) liquid; (c) liquid; (d) gas; (e) solid; (f) gas.

Check Your Learning

What phase changes can water undergo as the temperature changes if the pressure is held at 0.3 kPa? If the pressure is held at 50 kPa?

Answer: At 0.3 kPa: $s \rightarrow g$ at $-58\text{ }^{\circ}\text{C}$. At 50 kPa: $s \rightarrow l$ at $0\text{ }^{\circ}\text{C}$, $l \rightarrow g$ at $78\text{ }^{\circ}\text{C}$

Consider the phase diagram for carbon dioxide shown in **Figure 10.34** as another example. The solid-liquid curve exhibits a positive slope, indicating that the melting point for CO_2 increases with pressure as it does for most substances (water being a notable exception as described previously). Notice that the triple point is well above 1 atm, indicating that carbon dioxide cannot exist as a liquid under ambient pressure conditions. Instead, cooling gaseous carbon dioxide at 1 atm results in its deposition into the solid state. Likewise, solid carbon dioxide does not melt at

1 atm pressure but instead sublimates to yield gaseous CO_2 . Finally, notice that the critical point for carbon dioxide is observed at a relatively modest temperature and pressure in comparison to water.

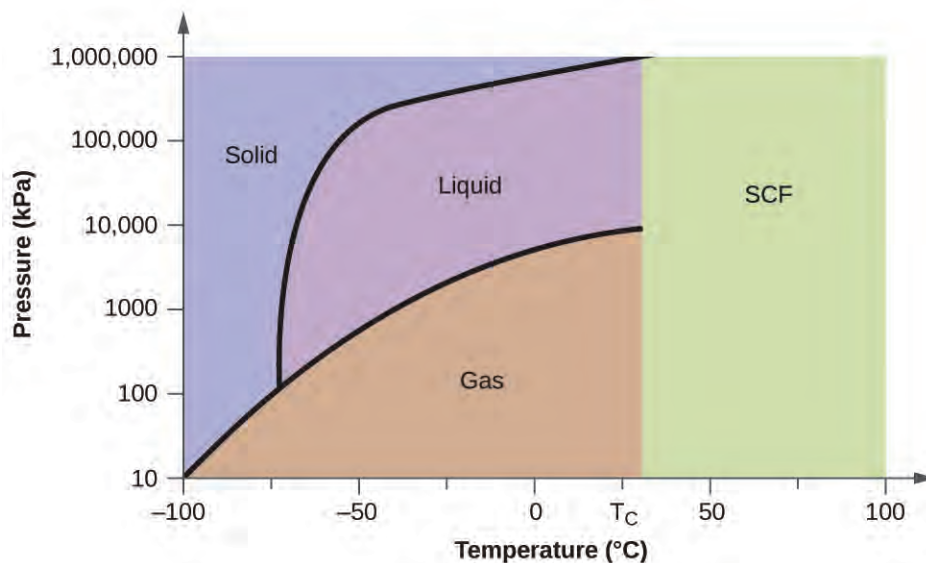

Figure 10.34 The pressure and temperature axes on this phase diagram of carbon dioxide are not drawn to constant scale in order to illustrate several important properties.

Example 10.12

Determining the State of Carbon Dioxide

Using the phase diagram for carbon dioxide shown in **Figure 10.34**, determine the state of CO_2 at the following temperatures and pressures:

- (a) -30°C and 2000 kPa
- (b) -60°C and 1000 kPa
- (c) -60°C and 100 kPa
- (d) 20°C and 1500 kPa
- (e) 0°C and 100 kPa
- (f) 20°C and 100 kPa

Solution

Using the phase diagram for carbon dioxide provided, we can determine that the state of CO_2 at each temperature and pressure given are as follows: (a) liquid; (b) solid; (c) gas; (d) liquid; (e) gas; (f) gas.

Check Your Learning

Determine the phase changes carbon dioxide undergoes when its temperature is varied, thus holding its pressure constant at 1500 kPa? At 500 kPa? At what approximate temperatures do these phase changes occur?

Answer: at 1500 kPa: $s \rightarrow l$ at -45°C , $l \rightarrow g$ at -10°C ; at 500 kPa: $s \rightarrow g$ at -58°C

Supercritical Fluids

If we place a sample of water in a sealed container at 25 °C, remove the air, and let the vaporization-condensation equilibrium establish itself, we are left with a mixture of liquid water and water vapor at a pressure of 0.03 atm. A distinct boundary between the more dense liquid and the less dense gas is clearly observed. As we increase the temperature, the pressure of the water vapor increases, as described by the liquid-gas curve in the phase diagram for water (**Figure 10.31**), and a two-phase equilibrium of liquid and gaseous phases remains. At a temperature of 374 °C, the vapor pressure has risen to 218 atm, and any further increase in temperature results in the disappearance of the boundary between liquid and vapor phases. All of the water in the container is now present in a single phase whose physical properties are intermediate between those of the gaseous and liquid states. This phase of matter is called a **supercritical fluid**, and the temperature and pressure above which this phase exists is the **critical point** (**Figure 10.35**). Above its critical temperature, a gas cannot be liquefied no matter how much pressure is applied. The pressure required to liquefy a gas at its critical temperature is called the critical pressure. The critical temperatures and critical pressures of some common substances are given in **Table 10.3**.

Substance	Critical Temperature (K)	Critical Pressure (atm)
hydrogen	33.2	12.8
nitrogen	126.0	33.5
oxygen	154.3	49.7
carbon dioxide	304.2	73.0
ammonia	405.5	111.5
sulfur dioxide	430.3	77.7
water	647.1	217.7

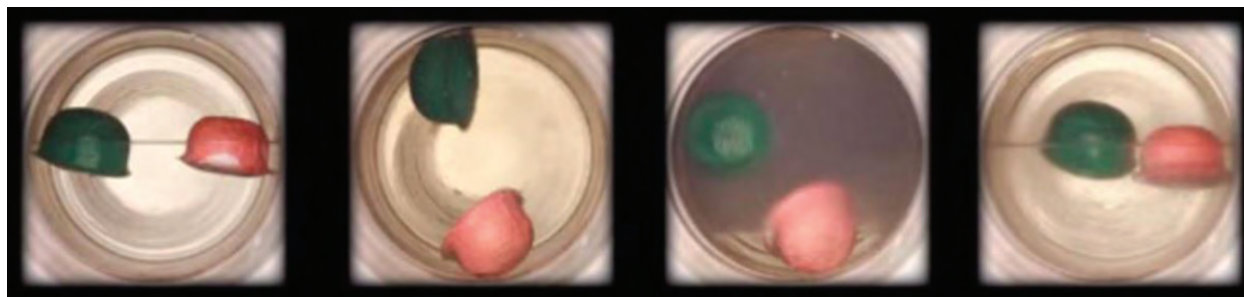

Figure 10.35 (a) A sealed container of liquid carbon dioxide slightly below its critical point is heated, resulting in (b) the formation of the supercritical fluid phase. Cooling the supercritical fluid lowers its temperature and pressure below the critical point, resulting in the reestablishment of separate liquid and gaseous phases (c and d). Colored floats illustrate differences in density between the liquid, gaseous, and supercritical fluid states. (credit: modification of work by “mrmrobin”/YouTube)

Link to Learning



Observe the **liquid-to-supercritical fluid transition** (<http://openstaxcollege.org/l/16supercrit>) for carbon dioxide.

Like a gas, a supercritical fluid will expand and fill a container, but its density is much greater than typical gas densities, typically being close to those for liquids. Similar to liquids, these fluids are capable of dissolving nonvolatile solutes. They exhibit essentially no surface tension and very low viscosities, however, so they can more effectively penetrate very small openings in a solid mixture and remove soluble components. These properties make supercritical fluids extremely useful solvents for a wide range of applications. For example, supercritical carbon dioxide has become a very popular solvent in the food industry, being used to decaffeinate coffee, remove fats from potato chips, and extract flavor and fragrance compounds from citrus oils. It is nontoxic, relatively inexpensive, and not considered to be a pollutant. After use, the CO_2 can be easily recovered by reducing the pressure and collecting the resulting gas.

Example 10.13

The Critical Temperature of Carbon Dioxide

If we shake a carbon dioxide fire extinguisher on a cool day (18°C), we can hear liquid CO_2 sloshing around inside the cylinder. However, the same cylinder appears to contain no liquid on a hot summer day (35°C). Explain these observations.

Solution

On the cool day, the temperature of the CO_2 is below the critical temperature of CO_2 , 304 K or 31°C (**Table 10.3**), so liquid CO_2 is present in the cylinder. On the hot day, the temperature of the CO_2 is greater than its critical temperature of 31°C . Above this temperature no amount of pressure can liquefy CO_2 so no liquid CO_2 exists in the fire extinguisher.

Check Your Learning

Ammonia can be liquefied by compression at room temperature; oxygen cannot be liquefied under these conditions. Why do the two gases exhibit different behavior?

Answer: The critical temperature of ammonia is 405.5 K, which is higher than room temperature. The critical temperature of oxygen is below room temperature; thus oxygen cannot be liquefied at room temperature.

Chemistry in Everyday Life

Decaffeinating Coffee Using Supercritical CO_2

Coffee is the world's second most widely traded commodity, following only petroleum. Across the globe, people love coffee's aroma and taste. Many of us also depend on one component of coffee—caffeine—to help us get going in the morning or stay alert in the afternoon. But late in the day, coffee's stimulant effect can keep you from sleeping, so you may choose to drink decaffeinated coffee in the evening.

Since the early 1900s, many methods have been used to decaffeinate coffee. All have advantages and disadvantages, and all depend on the physical and chemical properties of caffeine. Because caffeine is

a somewhat polar molecule, it dissolves well in water, a polar liquid. However, since many of the other 400-plus compounds that contribute to coffee's taste and aroma also dissolve in H_2O , hot water decaffeination processes can also remove some of these compounds, adversely affecting the smell and taste of the decaffeinated coffee. Dichloromethane (CH_2Cl_2) and ethyl acetate ($\text{CH}_3\text{CO}_2\text{C}_2\text{H}_5$) have similar polarity to caffeine, and are therefore very effective solvents for caffeine extraction, but both also remove some flavor and aroma components, and their use requires long extraction and cleanup times. Because both of these solvents are toxic, health concerns have been raised regarding the effect of residual solvent remaining in the decaffeinated coffee.

Supercritical fluid extraction using carbon dioxide is now being widely used as a more effective and environmentally friendly decaffeination method (Figure 10.36). At temperatures above 304.2 K and pressures above 7376 kPa, CO_2 is a supercritical fluid, with properties of both gas and liquid. Like a gas, it penetrates deep into the coffee beans; like a liquid, it effectively dissolves certain substances. Supercritical carbon dioxide extraction of steamed coffee beans removes 97–99% of the caffeine, leaving coffee's flavor and aroma compounds intact. Because CO_2 is a gas under standard conditions, its removal from the extracted coffee beans is easily accomplished, as is the recovery of the caffeine from the extract. The caffeine recovered from coffee beans via this process is a valuable product that can be used subsequently as an additive to other foods or drugs.

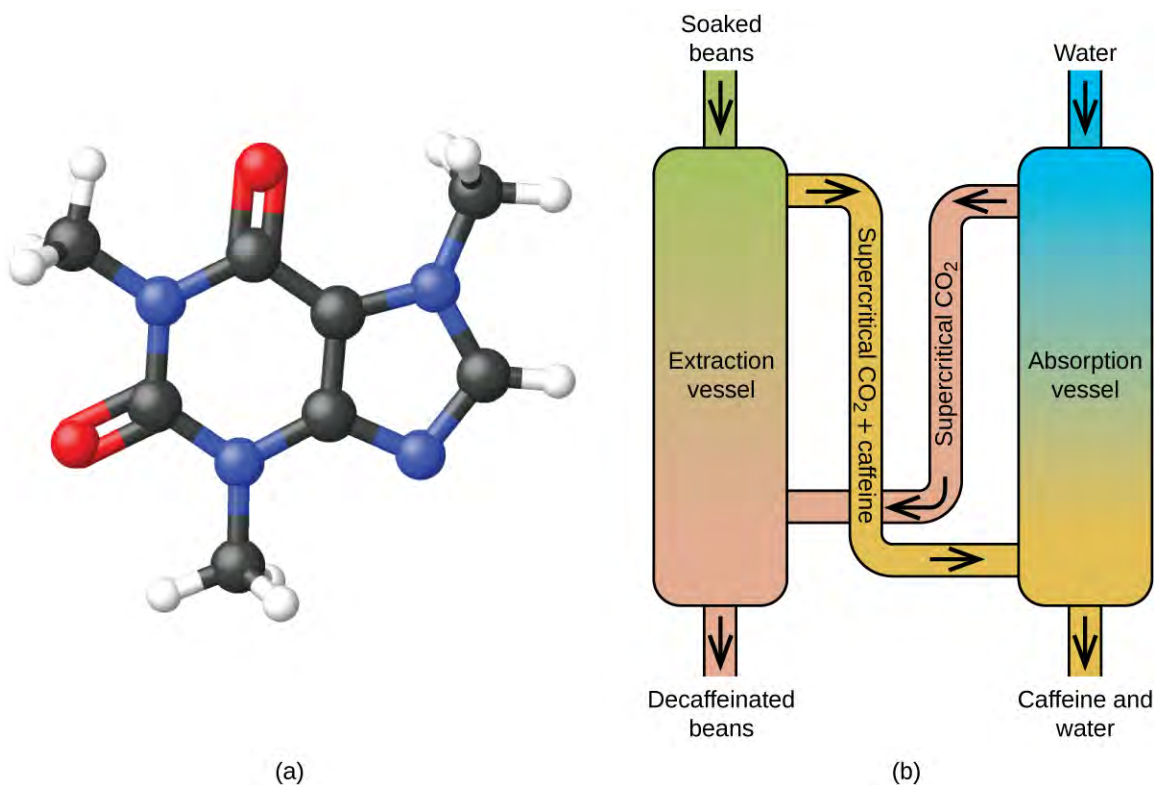

Figure 10.36 (a) Caffeine molecules have both polar and nonpolar regions, making it soluble in solvents of varying polarities. (b) The schematic shows a typical decaffeination process involving supercritical carbon dioxide.

10.5 The Solid State of Matter

By the end of this section, you will be able to:

- Define and describe the bonding and properties of ionic and molecular metallic and covalent network crystalline solids
- Describe the main types of crystalline solids: ionic solids, metallic solids, covalent network solids, and molecular solids
- Explain the ways in which crystal defects can occur in a solid

When most liquids are cooled, they eventually freeze and form **crystalline solids**, solids in which the atoms, ions, or molecules are arranged in a definite repeating pattern. It is also possible for a liquid to freeze before its molecules become arranged in an orderly pattern. The resulting materials are called **amorphous solids** or noncrystalline solids (or, sometimes, glasses). The particles of such solids lack an ordered internal structure and are randomly arranged (**Figure 10.37**).

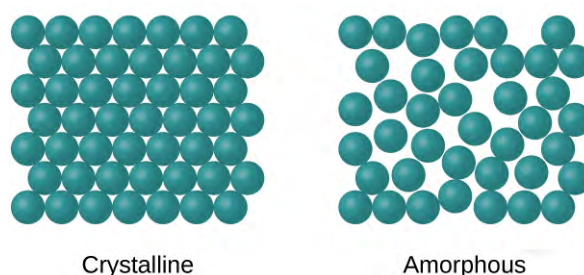

Figure 10.37 The entities of a solid phase may be arranged in a regular, repeating pattern (crystalline solids) or randomly (amorphous).

Metals and ionic compounds typically form ordered, crystalline solids. Substances that consist of large molecules, or a mixture of molecules whose movements are more restricted, often form amorphous solids. For examples, candle waxes are amorphous solids composed of large hydrocarbon molecules. Some substances, such as boron oxide (shown in **Figure 10.38**), can form either crystalline or amorphous solids, depending on the conditions under which it is produced. Also, amorphous solids may undergo a transition to the crystalline state under appropriate conditions.

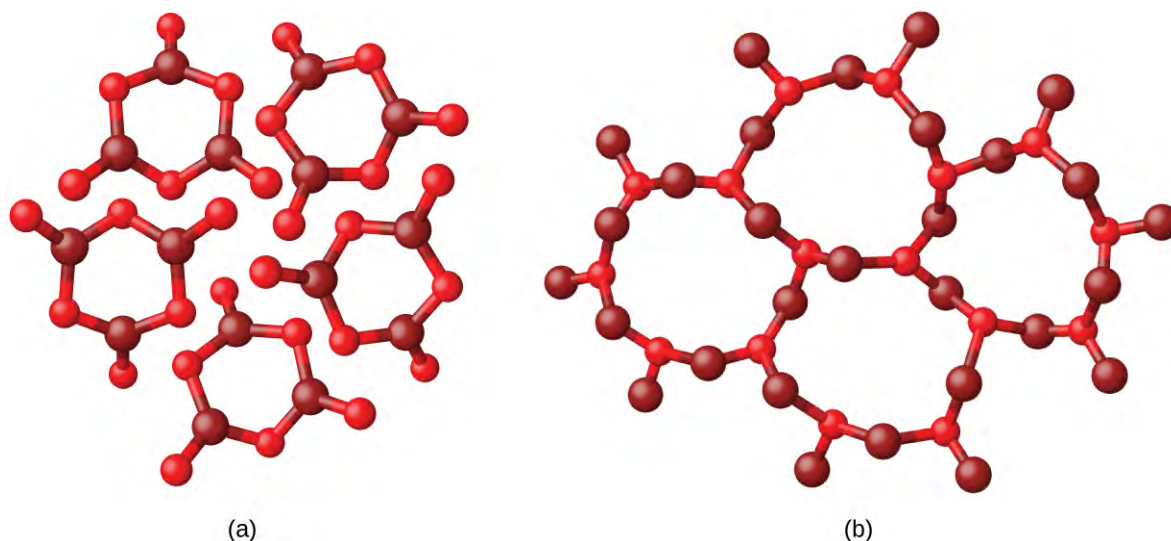

Figure 10.38 (a) Diboron trioxide, B_2O_3 , is normally found as a white, amorphous solid (a glass), which has a high degree of disorder in its structure. (b) By careful, extended heating, it can be converted into a crystalline form of B_2O_3 , which has a very ordered arrangement.

Crystalline solids are generally classified according to the nature of the forces that hold its particles together. These forces are primarily responsible for the physical properties exhibited by the bulk solids. The following sections provide descriptions of the major types of crystalline solids: ionic, metallic, covalent network, and molecular.

Ionic Solids

Ionic solids, such as sodium chloride and nickel oxide, are composed of positive and negative ions that are held together by electrostatic attractions, which can be quite strong (**Figure 10.39**). Many ionic crystals also have high melting points. This is due to the very strong attractions between the ions—in ionic compounds, the attractions between full charges are (much) larger than those between the partial charges in polar molecular compounds. This will be looked at in more detail in a later discussion of lattice energies. Although they are hard, they also tend to be brittle, and they shatter rather than bend. Ionic solids do not conduct electricity; however, they do conduct when molten or dissolved because their ions are free to move. Many simple compounds formed by the reaction of a metallic element with a nonmetallic element are ionic.

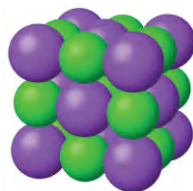

Figure 10.39 Sodium chloride is an ionic solid.

Metallic Solids

Metallic solids such as crystals of copper, aluminum, and iron are formed by metal atoms (**Figure 10.40**). The structure of metallic crystals is often described as a uniform distribution of atomic nuclei within a “sea” of delocalized electrons. The atoms within such a metallic solid are held together by a unique force known as *metallic bonding* that gives rise to many useful and varied bulk properties. All exhibit high thermal and electrical conductivity, metallic

luster, and malleability. Many are very hard and quite strong. Because of their malleability (the ability to deform under pressure or hammering), they do not shatter and, therefore, make useful construction materials. The melting points of the metals vary widely. Mercury is a liquid at room temperature, and the alkali metals melt below 200 °C. Several post-transition metals also have low melting points, whereas the transition metals melt at temperatures above 1000 °C. These differences reflect differences in strengths of metallic bonding among the metals.

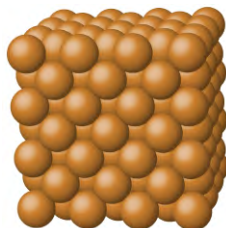

Figure 10.40 Copper is a metallic solid.

Covalent Network Solid

Covalent network solids include crystals of diamond, silicon, some other nonmetals, and some covalent compounds such as silicon dioxide (sand) and silicon carbide (carborundum, the abrasive on sandpaper). Many minerals have networks of covalent bonds. The atoms in these solids are held together by a network of covalent bonds, as shown in **Figure 10.41**. To break or to melt a covalent network solid, covalent bonds must be broken. Because covalent bonds are relatively strong, covalent network solids are typically characterized by hardness, strength, and high melting points. For example, diamond is one of the hardest substances known and melts above 3500 °C.

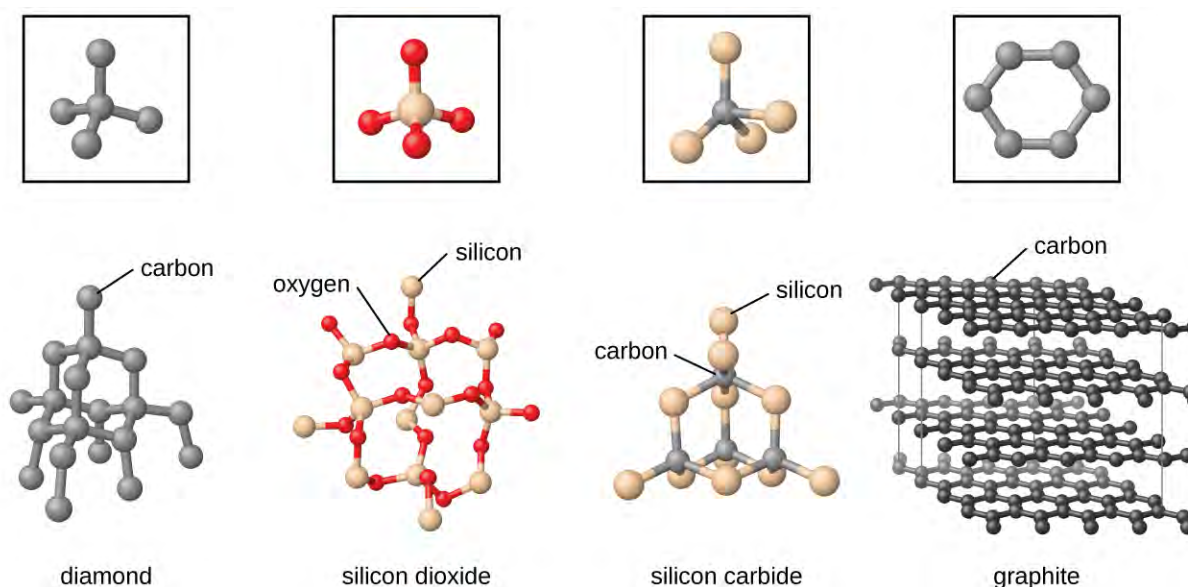

Figure 10.41 A covalent crystal contains a three-dimensional network of covalent bonds, as illustrated by the structures of diamond, silicon dioxide, silicon carbide, and graphite. Graphite is an exceptional example, composed of planar sheets of covalent crystals that are held together in layers by noncovalent forces. Unlike typical covalent solids, graphite is very soft and electrically conductive.

Molecular Solid

Molecular solids, such as ice, sucrose (table sugar), and iodine, as shown in **Figure 10.42**, are composed of neutral molecules. The strengths of the attractive forces between the units present in different crystals vary widely, as indicated by the melting points of the crystals. Small symmetrical molecules (nonpolar molecules), such as H_2 , N_2 , O_2 , and F_2 , have weak attractive forces and form molecular solids with very low melting points (below -200°C). Substances consisting of larger, nonpolar molecules have larger attractive forces and melt at higher temperatures. Molecular solids composed of molecules with permanent dipole moments (polar molecules) melt at still higher temperatures. Examples include ice (melting point, 0°C) and table sugar (melting point, 185°C).

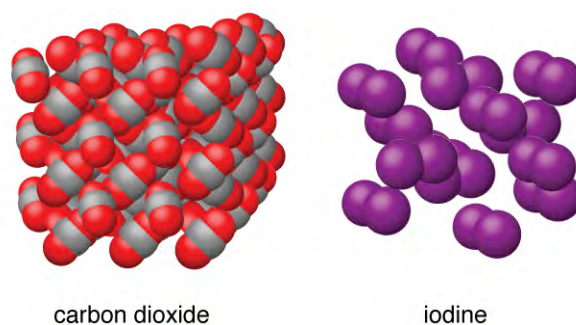

Figure 10.42 Carbon dioxide (CO_2) consists of small, nonpolar molecules and forms a molecular solid with a melting point of -78°C . Iodine (I_2) consists of larger, nonpolar molecules and forms a molecular solid that melts at 114°C .

Properties of Solids

A crystalline solid, like those listed in **Table 10.4**, has a precise melting temperature because each atom or molecule of the same type is held in place with the same forces or energy. Thus, the attractions between the units that make up the crystal all have the same strength and all require the same amount of energy to be broken. The gradual softening of an amorphous material differs dramatically from the distinct melting of a crystalline solid. This results from the structural nonequivalence of the molecules in the amorphous solid. Some forces are weaker than others, and when an amorphous material is heated, the weakest intermolecular attractions break first. As the temperature is increased further, the stronger attractions are broken. Thus amorphous materials soften over a range of temperatures.

Types of Crystalline Solids and Their Properties

Type of Solid	Type of Particles	Type of Attractions	Properties	Examples
ionic	ions	ionic bonds	hard, brittle, conducts electricity as a liquid but not as a solid, high to very high melting points	NaCl , Al_2O_3
metallic	atoms of electropositive elements	metallic bonds	shiny, malleable, ductile, conducts heat and electricity well, variable hardness and melting temperature	Cu , Fe , Ti , Pb , U
covalent network	atoms of electronegative elements	covalent bonds	very hard, not conductive, very high melting points	C (diamond), SiO_2 , SiC
molecular	molecules (or atoms)	IMFs	variable hardness, variable brittleness, not conductive, low melting points	H_2O , CO_2 , I_2 , $\text{C}_{12}\text{H}_{22}\text{O}_{11}$

Table 10.4

How Sciences Interconnect

Graphene: Material of the Future

Carbon is an essential element in our world. The unique properties of carbon atoms allow the existence of carbon-based life forms such as ourselves. Carbon forms a huge variety of substances that we use on a daily basis, including those shown in **Figure 10.43**. You may be familiar with diamond and graphite, the two most common *allotropes* of carbon. (Allotropes are different structural forms of the same element.) Diamond is one of the hardest-known substances, whereas graphite is soft enough to be used as pencil lead. These very different properties stem from the different arrangements of the carbon atoms in the different allotropes.

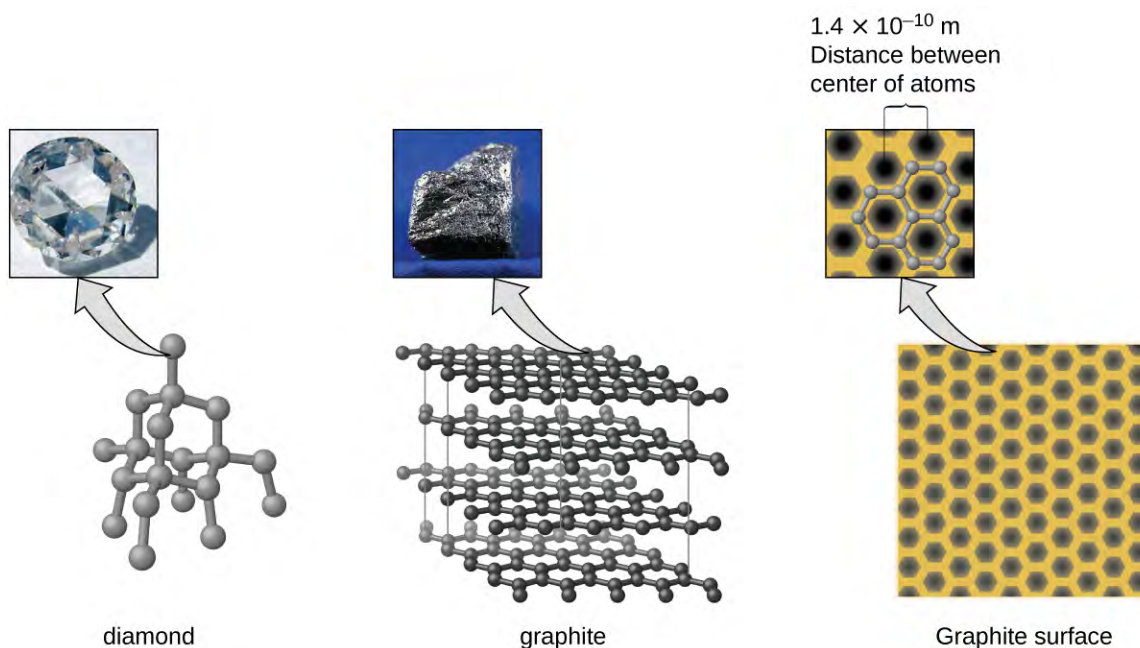

Figure 10.43 Diamond is extremely hard because of the strong bonding between carbon atoms in all directions. Graphite (in pencil lead) rubs off onto paper due to the weak attractions between the carbon layers. An image of a graphite surface shows the distance between the centers of adjacent carbon atoms. (credit left photo: modification of work by Steve Jurvetson; credit middle photo: modification of work by United States Geological Survey)

You may be less familiar with a recently discovered form of carbon: graphene. Graphene was first isolated in 2004 by using tape to peel off thinner and thinner layers from graphite. It is essentially a single sheet (one atom thick) of graphite. Graphene, illustrated in **Figure 10.44**, is not only strong and lightweight, but it is also an excellent conductor of electricity and heat. These properties may prove very useful in a wide range of applications, such as vastly improved computer chips and circuits, better batteries and solar cells, and stronger and lighter structural materials. The 2010 Nobel Prize in Physics was awarded to Andre Geim and Konstantin Novoselov for their pioneering work with graphene.

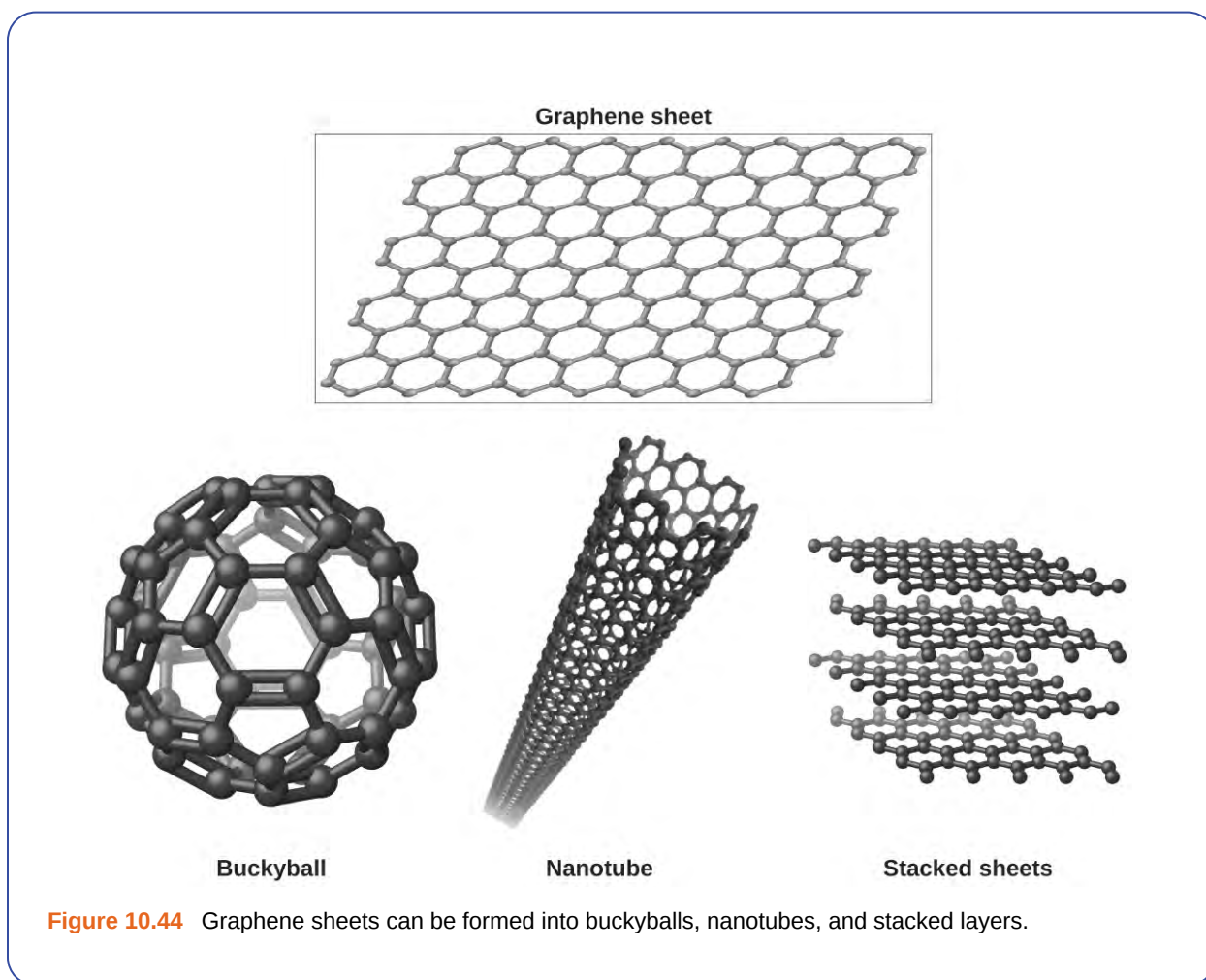

Figure 10.44 Graphene sheets can be formed into buckyballs, nanotubes, and stacked layers.

Crystal Defects

In a crystalline solid, the atoms, ions, or molecules are arranged in a definite repeating pattern, but occasional defects may occur in the pattern. Several types of defects are known, as illustrated in **Figure 10.45**. **Vacancies** are defects that occur when positions that should contain atoms or ions are vacant. Less commonly, some atoms or ions in a crystal may occupy positions, called **interstitial sites**, located between the regular positions for atoms. Other distortions are found in impure crystals, as, for example, when the cations, anions, or molecules of the impurity are too large to fit into the regular positions without distorting the structure. Trace amounts of impurities are sometimes added to a crystal (a process known as *doping*) in order to create defects in the structure that yield desirable changes in its properties. For example, silicon crystals are doped with varying amounts of different elements to yield suitable electrical properties for their use in the manufacture of semiconductors and computer chips.

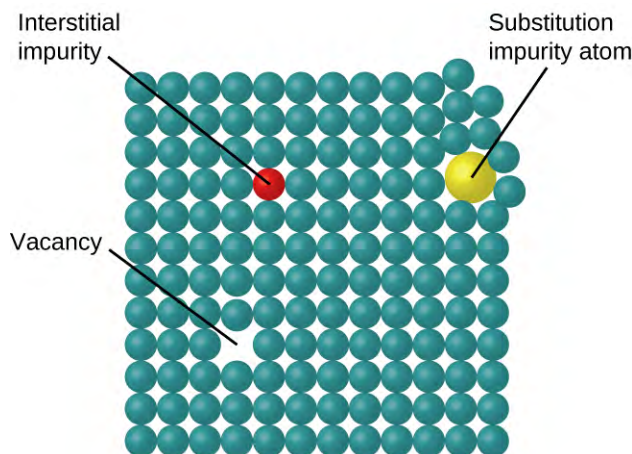

Figure 10.45 Types of crystal defects include vacancies, interstitial atoms, and substitutions impurities.

10.6 Lattice Structures in Crystalline Solids

By the end of this section, you will be able to:

- Describe the arrangement of atoms and ions in crystalline structures
- Compute ionic radii using unit cell dimensions
- Explain the use of X-ray diffraction measurements in determining crystalline structures

Over 90% of naturally occurring and man-made solids are crystalline. Most solids form with a regular arrangement of their particles because the overall attractive interactions between particles are maximized, and the total intermolecular energy is minimized, when the particles pack in the most efficient manner. The regular arrangement at an atomic level is often reflected at a macroscopic level. In this module, we will explore some of the details about the structures of metallic and ionic crystalline solids, and learn how these structures are determined experimentally.

The Structures of Metals

We will begin our discussion of crystalline solids by considering elemental metals, which are relatively simple because each contains only one type of atom. A pure metal is a crystalline solid with metal atoms packed closely together in a repeating pattern. Some of the properties of metals in general, such as their malleability and ductility, are largely due to having identical atoms arranged in a regular pattern. The different properties of one metal compared to another partially depend on the sizes of their atoms and the specifics of their spatial arrangements. We will explore the similarities and differences of four of the most common metal crystal geometries in the sections that follow.

Unit Cells of Metals

The structure of a crystalline solid, whether a metal or not, is best described by considering its simplest repeating unit, which is referred to as its **unit cell**. The unit cell consists of lattice points that represent the locations of atoms or ions. The entire structure then consists of this unit cell repeating in three dimensions, as illustrated in **Figure 10.46**.

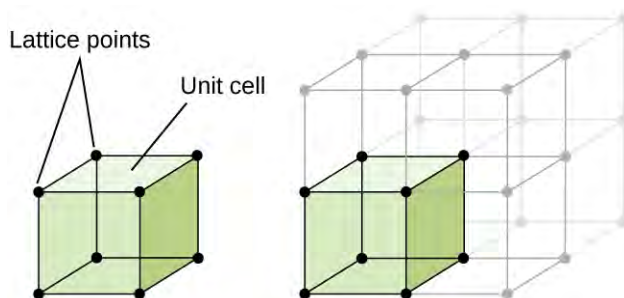

Figure 10.46 A unit cell shows the locations of lattice points repeating in all directions.

Let us begin our investigation of crystal lattice structure and unit cells with the most straightforward structure and the most basic unit cell. To visualize this, imagine taking a large number of identical spheres, such as tennis balls, and arranging them uniformly in a container. The simplest way to do this would be to make layers in which the spheres in one layer are directly above those in the layer below, as illustrated in **Figure 10.47**. This arrangement is called **simple cubic structure**, and the unit cell is called the **simple cubic unit cell** or primitive cubic unit cell.

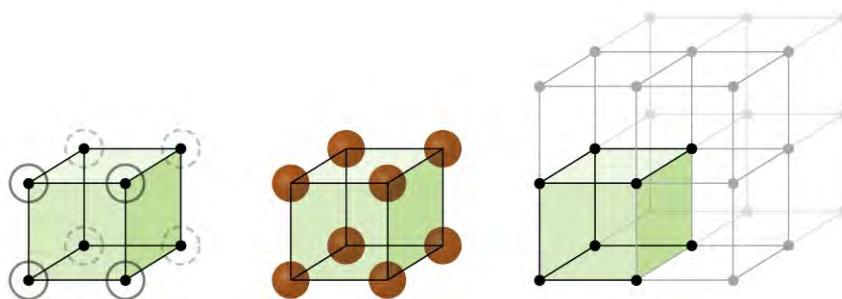

Figure 10.47 When metal atoms are arranged with spheres in one layer directly above or below spheres in another layer, the lattice structure is called simple cubic. Note that the spheres are in contact.

In a simple cubic structure, the spheres are not packed as closely as they could be, and they only “fill” about 52% of the volume of the container. This is a relatively inefficient arrangement, and only one metal (polonium, Po) crystallizes in a simple cubic structure. As shown in **Figure 10.48**, a solid with this type of arrangement consists of planes (or layers) in which each atom contacts only the four nearest neighbors in its layer; one atom directly above it in the layer above; and one atom directly below it in the layer below. The number of other particles that each particle in a crystalline solid contacts is known as its **coordination number**. For a polonium atom in a simple cubic array, the coordination number is, therefore, six.

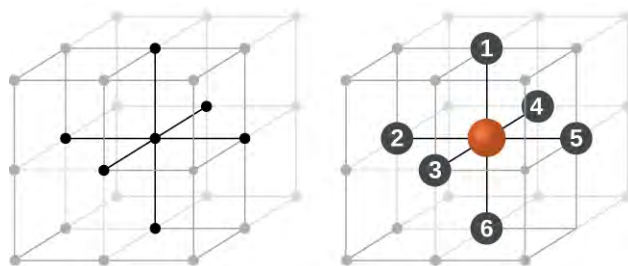

Figure 10.48 An atom in a simple cubic lattice structure contacts six other atoms, so it has a coordination number of six.

In a simple cubic lattice, the unit cell that repeats in all directions is a cube defined by the centers of eight atoms, as shown in **Figure 10.49**. Atoms at adjacent corners of this unit cell contact each other, so the edge length of this cell is equal to two atomic radii, or one atomic diameter. A cubic unit cell contains only the parts of these atoms that are within it. Since an atom at a corner of a simple cubic unit cell is contained by a total of eight unit cells, only one-eighth of that atom is within a specific unit cell. And since each simple cubic unit cell has one atom at each of its eight “corners,” there is $8 \times \frac{1}{8} = 1$ atom within one simple cubic unit cell.

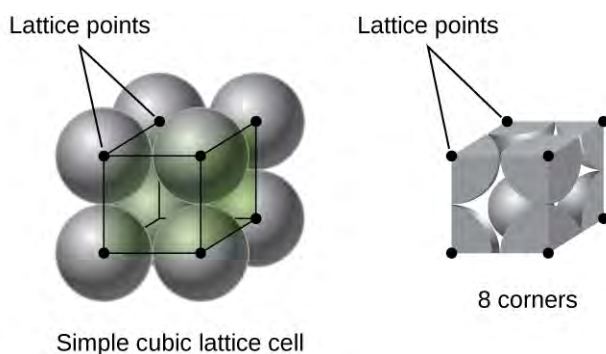

Figure 10.49 A simple cubic lattice unit cell contains one-eighth of an atom at each of its eight corners, so it contains one atom total.

Example 10.14

Calculation of Atomic Radius and Density for Metals, Part 1

The edge length of the unit cell of alpha polonium is 336 pm.

- Determine the radius of a polonium atom.
- Determine the density of alpha polonium.

Solution

Alpha polonium crystallizes in a simple cubic unit cell:

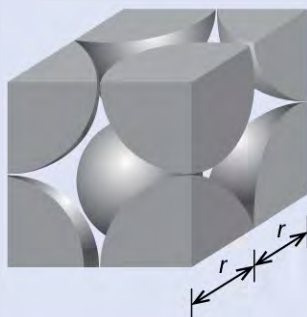

(a) Two adjacent Po atoms contact each other, so the edge length of this cell is equal to two Po atomic radii: $l = 2r$. Therefore, the radius of Po is $r = \frac{1}{2}l = \frac{336 \text{ pm}}{2} = 168 \text{ pm}$.

(b) Density is given by $\text{density} = \frac{\text{mass}}{\text{volume}}$. The density of polonium can be found by determining the density of its unit cell (the mass contained within a unit cell divided by the volume of the unit cell). Since a Po unit cell contains one-eighth of a Po atom at each of its eight corners, a unit cell contains one Po atom.

The mass of a Po unit cell can be found by:

$$1 \text{ Po unit cell} \times \frac{1 \text{ Po atom}}{1 \text{ Po unit cell}} \times \frac{1 \text{ mol Po}}{6.022 \times 10^{23} \text{ Po atoms}} \times \frac{208.998 \text{ g}}{1 \text{ mol Po}} = 3.47 \times 10^{-22} \text{ g}$$

The volume of a Po unit cell can be found by:

$$V = l^3 = (336 \times 10^{-10} \text{ cm})^3 = 3.79 \times 10^{-23} \text{ cm}^3$$

(Note that the edge length was converted from pm to cm to get the usual volume units for density.)

$$\text{Therefore, the density of Po} = \frac{3.471 \times 10^{-22} \text{ g}}{3.79 \times 10^{-23} \text{ cm}^3} = 9.16 \text{ g/cm}^3$$

Check Your Learning

The edge length of the unit cell for nickel is 0.3524 nm. The density of Ni is 8.90 g/cm³. Does nickel crystallize in a simple cubic structure? Explain.

Answer: No. If Ni was simple cubic, its density would be given by:

$$1 \text{ Ni atom} \times \frac{1 \text{ mol Ni}}{6.022 \times 10^{23} \text{ Ni atoms}} \times \frac{58.693 \text{ g}}{1 \text{ mol Ni}} = 9.746 \times 10^{-23} \text{ g}$$

$$V = l^3 = (3.524 \times 10^{-8} \text{ cm})^3 = 4.376 \times 10^{-23} \text{ cm}^3$$

$$\text{Then the density of Ni would be} = \frac{9.746 \times 10^{-23} \text{ g}}{4.376 \times 10^{-23} \text{ cm}^3} = 2.23 \text{ g/cm}^3$$

Since the actual density of Ni is not close to this, Ni does not form a simple cubic structure.

Most metal crystals are one of the four major types of unit cells. For now, we will focus on the three cubic unit cells: simple cubic (which we have already seen), **body-centered cubic unit cell**, and **face-centered cubic unit cell**—all of which are illustrated in **Figure 10.50**. (Note that there are actually seven different lattice systems, some of which have more than one type of lattice, for a total of 14 different types of unit cells. We leave the more complicated geometries for later in this module.)

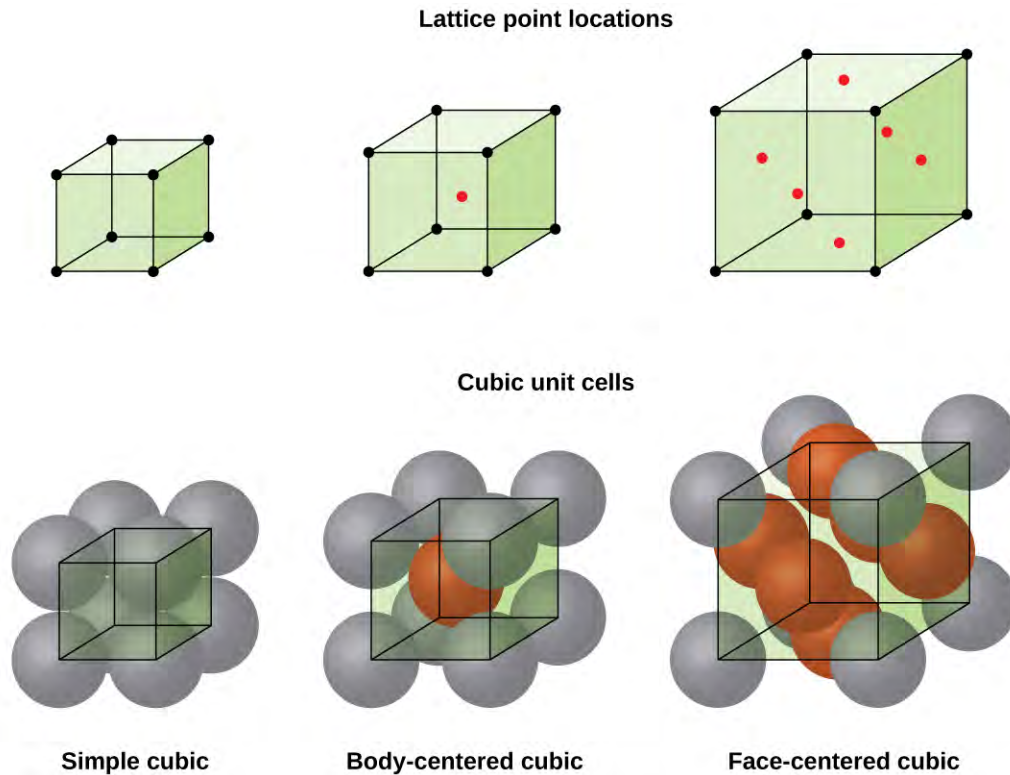

Figure 10.50 Cubic unit cells of metals show (in the upper figures) the locations of lattice points and (in the lower figures) metal atoms located in the unit cell.

Some metals crystallize in an arrangement that has a cubic unit cell with atoms at all of the corners and an atom in the center, as shown in **Figure 10.51**. This is called a **body-centered cubic (BCC) solid**. Atoms in the corners of a BCC unit cell do not contact each other but contact the atom in the center. A BCC unit cell contains two atoms: one-eighth of an atom at each of the eight corners ($8 \times \frac{1}{8} = 1$ atom from the corners) plus one atom from the center. Any atom in this structure touches four atoms in the layer above it and four atoms in the layer below it. Thus, an atom in a BCC structure has a coordination number of eight.

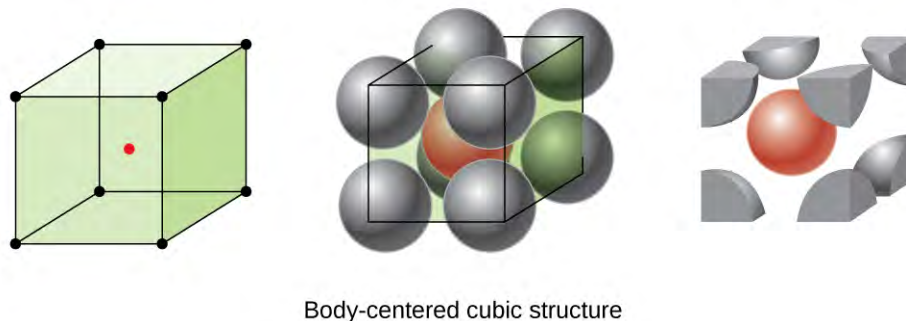
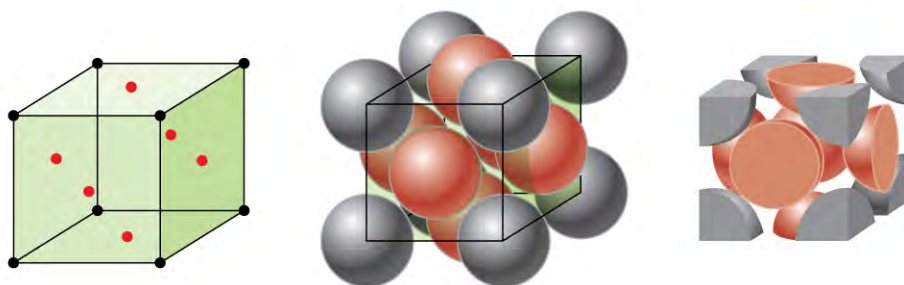

Figure 10.51 In a body-centered cubic structure, atoms in a specific layer do not touch each other. Each atom touches four atoms in the layer above it and four atoms in the layer below it.

Atoms in BCC arrangements are much more efficiently packed than in a simple cubic structure, occupying about 68% of the total volume. Isomorphous metals with a BCC structure include K, Ba, Cr, Mo, W, and Fe at room temperature. (Elements or compounds that crystallize with the same structure are said to be **isomorphous**.)

Many other metals, such as aluminum, copper, and lead, crystallize in an arrangement that has a cubic unit cell with atoms at all of the corners and at the centers of each face, as illustrated in **Figure 10.52**. This arrangement is called a **face-centered cubic (FCC) solid**. A FCC unit cell contains four atoms: one-eighth of an atom at each of the eight corners ($8 \times \frac{1}{8} = 1$ atom from the corners) and one-half of an atom on each of the six faces ($6 \times \frac{1}{2} = 3$ atoms from the faces). The atoms at the corners touch the atoms in the centers of the adjacent faces along the face diagonals of the cube. Because the atoms are on identical lattice points, they have identical environments.



Face-centered cubic structure

Figure 10.52 A face-centered cubic solid has atoms at the corners and, as the name implies, at the centers of the faces of its unit cells.

Atoms in an FCC arrangement are packed as closely together as possible, with atoms occupying 74% of the volume. This structure is also called **cubic closest packing (CCP)**. In CCP, there are three repeating layers of hexagonally arranged atoms. Each atom contacts six atoms in its own layer, three in the layer above, and three in the layer below. In this arrangement, each atom touches 12 near neighbors, and therefore has a coordination number of 12. The fact that FCC and CCP arrangements are equivalent may not be immediately obvious, but why they are actually the same structure is illustrated in **Figure 10.53**.

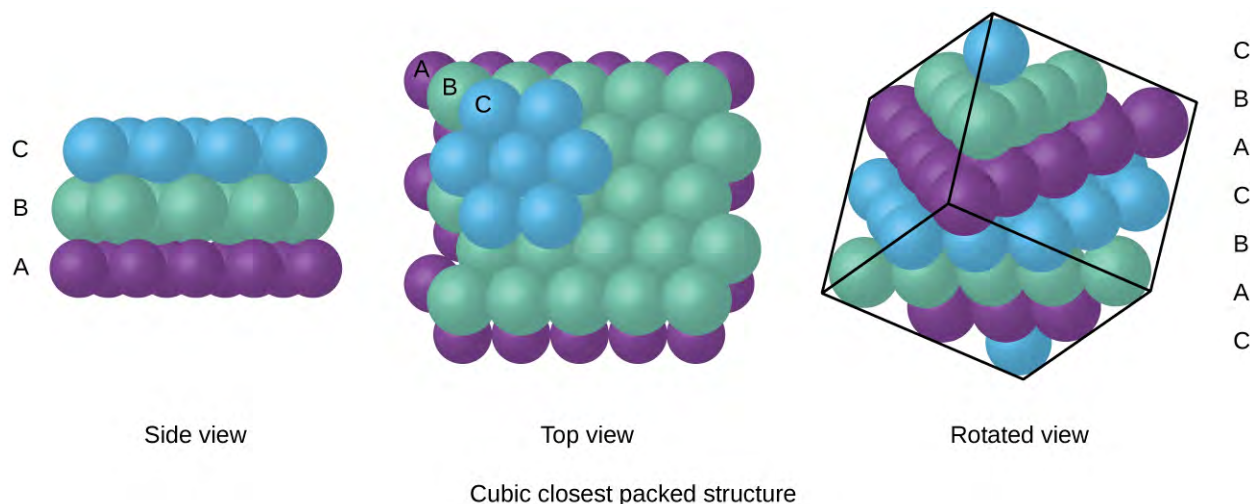

Figure 10.53 A CCP arrangement consists of three repeating layers (ABCABC...) of hexagonally arranged atoms. Atoms in a CCP structure have a coordination number of 12 because they contact six atoms in their layer, plus three atoms in the layer above and three atoms in the layer below. By rotating our perspective, we can see that a CCP structure has a unit cell with a face containing an atom from layer A at one corner, atoms from layer B across a diagonal (at two corners and in the middle of the face), and an atom from layer C at the remaining corner. This is the same as a face-centered cubic arrangement.

Because closer packing maximizes the overall attractions between atoms and minimizes the total intermolecular energy, the atoms in most metals pack in this manner. We find two types of closest packing in simple metallic crystalline structures: CCP, which we have already encountered, and **hexagonal closest packing (HCP)** shown in **Figure 10.54**. Both consist of repeating layers of hexagonally arranged atoms. In both types, a second layer (B) is placed on the first layer (A) so that each atom in the second layer is in contact with three atoms in the first layer. The third layer is positioned in one of two ways. In HCP, atoms in the third layer are directly above atoms in the first layer (i.e., the third layer is also type A), and the stacking consists of alternating type A and type B close-packed layers (i.e., ABABAB...). In CCP, atoms in the third layer are not above atoms in either of the first two layers (i.e., the third layer is type C), and the stacking consists of alternating type A, type B, and type C close-packed layers (i.e., ABCABCABC...). About two-thirds of all metals crystallize in closest-packed arrays with coordination numbers of 12. Metals that crystallize in an HCP structure include Cd, Co, Li, Mg, Na, and Zn, and metals that crystallize in a CCP structure include Ag, Al, Ca, Cu, Ni, Pb, and Pt.

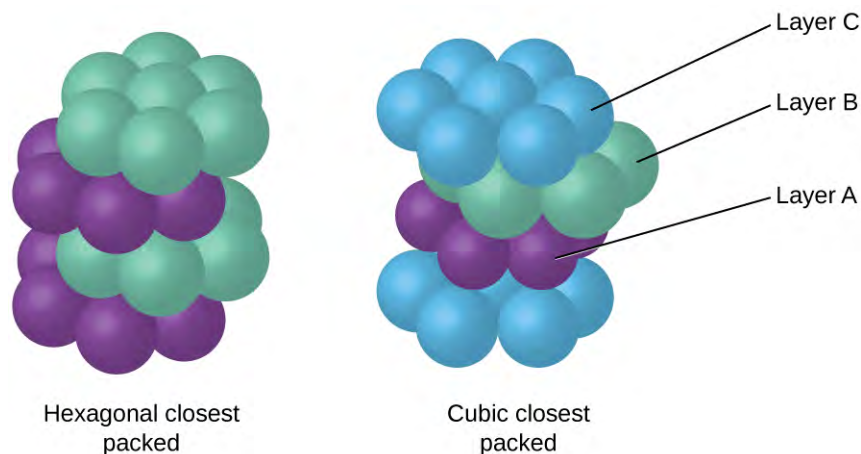

Figure 10.54 In both types of closest packing, atoms are packed as compactly as possible. Hexagonal closest packing consists of two alternating layers (ABABAB...). Cubic closest packing consists of three alternating layers (ABCABCABC...).

Example 10.15

Calculation of Atomic Radius and Density for Metals, Part 2

Calcium crystallizes in a face-centered cubic structure. The edge length of its unit cell is 558.8 pm.

- What is the atomic radius of Ca in this structure?
- Calculate the density of Ca.

Solution

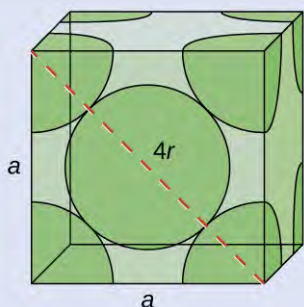

(a) In an FCC structure, Ca atoms contact each other across the diagonal of the face, so the length of the diagonal is equal to four Ca atomic radii ($d = 4r$). Two adjacent edges and the diagonal of the face form a right triangle, with the length of each side equal to 558.8 pm and the length of the hypotenuse equal to four Ca atomic radii:

$$a^2 + a^2 = d^2 \longrightarrow (558.8 \text{ pm})^2 + (558.5 \text{ pm})^2 = (4r)^2$$

Solving this gives $r = \sqrt{\frac{(558.8 \text{ pm})^2 + (558.5 \text{ pm})^2}{16}} = 197.6 \text{ pm}$ for a Ca radius.

(b) Density is given by $\text{density} = \frac{\text{mass}}{\text{volume}}$. The density of calcium can be found by determining the density of its unit cell: for example, the mass contained within a unit cell divided by the volume of the unit cell.

A face-centered Ca unit cell has one-eighth of an atom at each of the eight corners ($8 \times \frac{1}{8} = 1$ atom) and one-half of an atom on each of the six faces ($6 \times \frac{1}{2} = 3$ atoms), for a total of four atoms in the unit cell.

The mass of the unit cell can be found by:

$$1 \text{ Ca unit cell} \times \frac{4 \text{ Ca atoms}}{1 \text{ Ca unit cell}} \times \frac{1 \text{ mol Ca}}{6.022 \times 10^{23} \text{ Ca atoms}} \times \frac{40.078 \text{ g}}{1 \text{ mol Ca}} = 2.662 \times 10^{-22} \text{ g}$$

The volume of a Ca unit cell can be found by:

$$V = a^3 = (558.8 \times 10^{-10} \text{ cm})^3 = 1.745 \times 10^{-22} \text{ cm}^3$$

(Note that the edge length was converted from pm to cm to get the usual volume units for density.)

$$\text{Then, the density of Po} = \frac{2.662 \times 10^{-22} \text{ g}}{1.745 \times 10^{-22} \text{ cm}^3} = 1.53 \text{ g/cm}^3$$

Check Your Learning

Silver crystallizes in an FCC structure. The edge length of its unit cell is 409 pm.

- What is the atomic radius of Ag in this structure?
- Calculate the density of Ag.

Answer: (a) 144 pm; (b) 10.5 g/cm³

In general, a unit cell is defined by the lengths of three axes (a , b , and c) and the angles (α , β , and γ) between them, as illustrated in **Figure 10.55**. The axes are defined as being the lengths between points in the space lattice. Consequently, unit cell axes join points with identical environments.

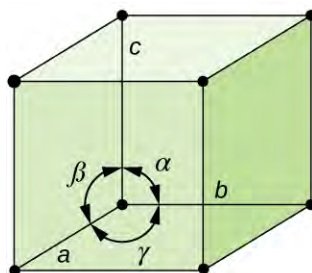

Figure 10.55 A unit cell is defined by the lengths of its three axes (a , b , and c) and the angles (α , β , and γ) between the axes.

There are seven different lattice systems, some of which have more than one type of lattice, for a total of fourteen different unit cells, which have the shapes shown in **Figure 10.56**.







System/Axes/Angles	Unit Cells			
Cubic $a = b = c$ $\alpha = \beta = \gamma = 90^\circ$				
	Simple	Face-centered	Body-centered	
Tetragonal $a = b \neq c$ $\alpha = \beta = \gamma = 90^\circ$				
	Simple	Body-centered		
Orthorhombic $a \neq b \neq c$ $\alpha = \beta = \gamma = 90^\circ$				
	Simple	Body-centered	Base-centered	Face-centered
Monoclinic $a \neq b \neq c$ $\alpha = \gamma = 90^\circ; \beta \neq 90^\circ$				
	Simple	Base-centered		
Triclinic $a \neq b \neq c$ $\alpha \neq \beta \neq \gamma \neq 90^\circ$				
Hexagonal $a = b \neq c$ $\alpha = \beta = 90^\circ; \gamma = 120^\circ$				
Rhombohedral $a = b = c$ $\alpha = \beta = \gamma \neq 90^\circ$				

Figure 10.56 There are seven different lattice systems and 14 different unit cells.

The Structures of Ionic Crystals

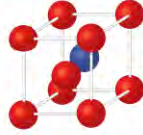
Ionic crystals consist of two or more different kinds of ions that usually have different sizes. The packing of these ions into a crystal structure is more complex than the packing of metal atoms that are the same size.

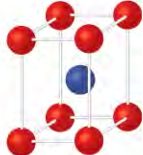
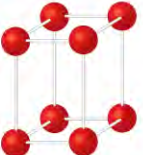
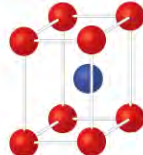
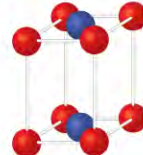
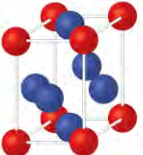
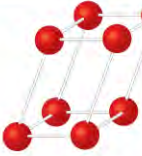
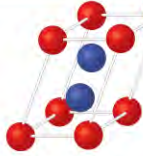
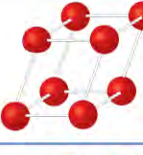
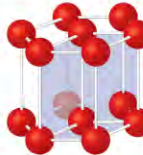
Most monatomic ions behave as charged spheres, and their attraction for ions of opposite charge is the same in every direction. Consequently, stable structures for ionic compounds result (1) when ions of one charge are surrounded by as many ions as possible of the opposite charge and (2) when the cations and anions are in contact with each other. Structures are determined by two principal factors: the relative sizes of the ions and the ratio of the numbers of positive and negative ions in the compound.

In simple ionic structures, we usually find the anions, which are normally larger than the cations, arranged in a closest-packed array. (As seen previously, additional electrons attracted to the same nucleus make anions larger and fewer electrons attracted to the same nucleus make cations smaller when compared to the atoms from which they are formed.) The smaller cations commonly occupy one of two types of **holes** (or interstices) remaining between the anions. The smaller of the holes is found between three anions in one plane and one anion in an adjacent plane. The four anions surrounding this hole are arranged at the corners of a tetrahedron, so the hole is called a **tetrahedral hole**. The larger type of hole is found at the center of six anions (three in one layer and three in an adjacent layer) located at the corners of an octahedron; this is called an **octahedral hole**. **Figure 10.57** illustrates both of these types of holes.

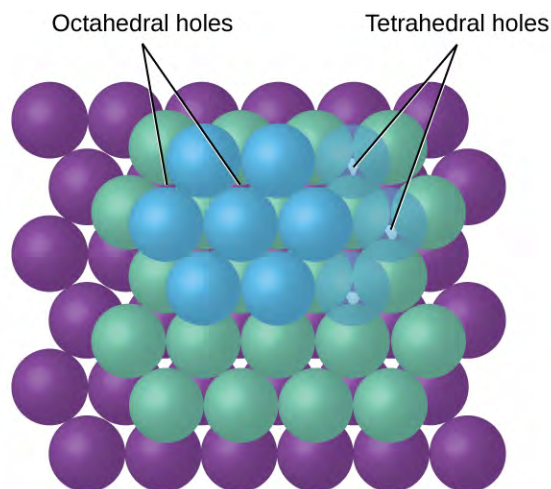

Figure 10.57 Cations may occupy two types of holes between anions: octahedral holes or tetrahedral holes.

Depending on the relative sizes of the cations and anions, the cations of an ionic compound may occupy tetrahedral or octahedral holes, as illustrated in **Figure 10.58**. Relatively small cations occupy tetrahedral holes, and larger cations occupy octahedral holes. If the cations are too large to fit into the octahedral holes, the anions may adopt a more open structure, such as a simple cubic array. The larger cations can then occupy the larger cubic holes made possible by the more open spacing.

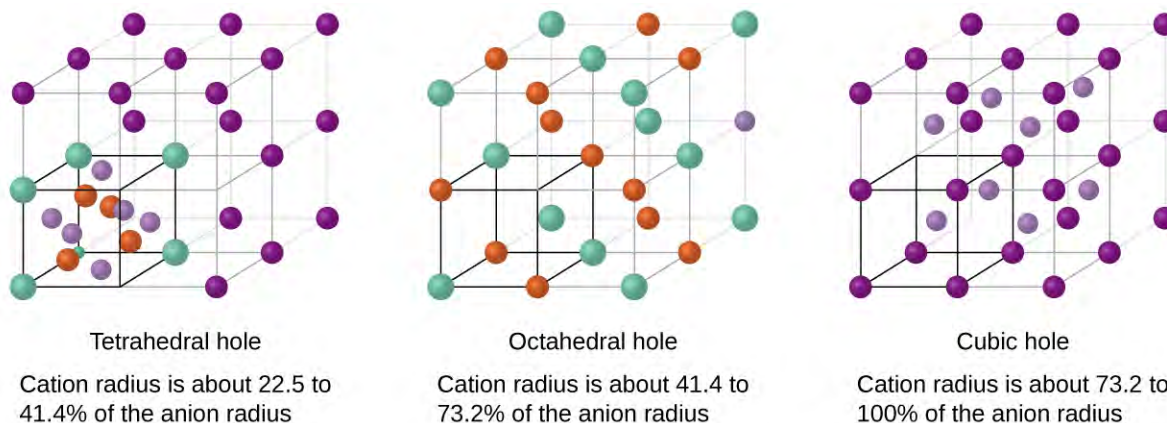

Figure 10.58 A cation's size and the shape of the hole occupied by the compound are directly related.

There are two tetrahedral holes for each anion in either an HCP or CCP array of anions. A compound that crystallizes in a closest-packed array of anions with cations in the tetrahedral holes can have a maximum cation:anion ratio of 2:1; all of the tetrahedral holes are filled at this ratio. Examples include Li_2O , Na_2O , Li_2S , and Na_2S . Compounds with a ratio of less than 2:1 may also crystallize in a closest-packed array of anions with cations in the tetrahedral holes, if the ionic sizes fit. In these compounds, however, some of the tetrahedral holes remain vacant.

Example 10.16

Occupancy of Tetrahedral Holes

Zinc sulfide is an important industrial source of zinc and is also used as a white pigment in paint. Zinc sulfide crystallizes with zinc ions occupying one-half of the tetrahedral holes in a closest-packed array of sulfide ions. What is the formula of zinc sulfide?

Solution

Because there are two tetrahedral holes per anion (sulfide ion) and one-half of these holes are occupied by zinc ions, there must be $\frac{1}{2} \times 2$, or 1, zinc ion per sulfide ion. Thus, the formula is ZnS .

Check Your Learning

Lithium selenide can be described as a closest-packed array of selenide ions with lithium ions in all of the tetrahedral holes. What is the formula of lithium selenide?

Answer: Li_2Se

The ratio of octahedral holes to anions in either an HCP or CCP structure is 1:1. Thus, compounds with cations in octahedral holes in a closest-packed array of anions can have a maximum cation:anion ratio of 1:1. In NiO , MnS , NaCl , and KH , for example, all of the octahedral holes are filled. Ratios of less than 1:1 are observed when some of the octahedral holes remain empty.

Example 10.17

Stoichiometry of Ionic Compounds

Sapphire is aluminum oxide. Aluminum oxide crystallizes with aluminum ions in two-thirds of the octahedral holes in a closest-packed array of oxide ions. What is the formula of aluminum oxide?

Solution

Because there is one octahedral hole per anion (oxide ion) and only two-thirds of these holes are occupied, the ratio of aluminum to oxygen must be $\frac{2}{3}:1$, which would give $\text{Al}_{2/3}\text{O}$. The simplest whole number ratio is 2:3, so the formula is Al_2O_3 .

Check Your Learning

The white pigment titanium oxide crystallizes with titanium ions in one-half of the octahedral holes in a closest-packed array of oxide ions. What is the formula of titanium oxide?

Answer: TiO_2

In a simple cubic array of anions, there is one cubic hole that can be occupied by a cation for each anion in the array. In CsCl , and in other compounds with the same structure, all of the cubic holes are occupied. Half of the cubic holes are occupied in SrH_2 , UO_2 , SrCl_2 , and CaF_2 .

Different types of ionic compounds often crystallize in the same structure when the relative sizes of their ions and their stoichiometries (the two principal features that determine structure) are similar.

Unit Cells of Ionic Compounds

Many ionic compounds crystallize with cubic unit cells, and we will use these compounds to describe the general features of ionic structures.

When an ionic compound is composed of cations and anions of similar size in a 1:1 ratio, it typically forms a simple cubic structure. Cesium chloride, CsCl , (illustrated in **Figure 10.59**) is an example of this, with Cs^+ and Cl^- having radii of 174 pm and 181 pm, respectively. We can think of this as chloride ions forming a simple cubic unit cell, with a cesium ion in the center; or as cesium ions forming a unit cell with a chloride ion in the center; or as simple cubic unit cells formed by Cs^+ ions overlapping unit cells formed by Cl^- ions. Cesium ions and chloride ions touch along the body diagonals of the unit cells. One cesium ion and one chloride ion are present per unit cell, giving the 1:1 stoichiometry required by the formula for cesium chloride. Note that there is no lattice point in the center of the cell, and CsCl is not a BCC structure because a cesium ion is not identical to a chloride ion.

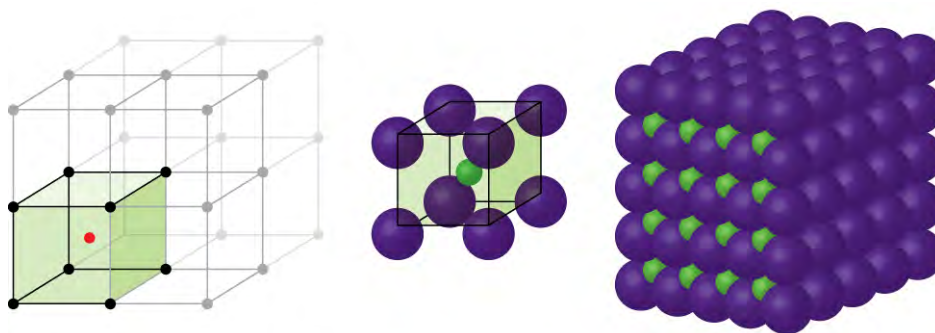

Body-centered simple cubic structure

Figure 10.59 Ionic compounds with similar-sized cations and anions, such as CsCl , usually form a simple cubic structure. They can be described by unit cells with either cations at the corners or anions at the corners.

We have said that the location of lattice points is arbitrary. This is illustrated by an alternate description of the CsCl structure in which the lattice points are located in the centers of the cesium ions. In this description, the cesium ions are located on the lattice points at the corners of the cell, and the chloride ion is located at the center of the cell. The two unit cells are different, but they describe identical structures.

When an ionic compound is composed of a 1:1 ratio of cations and anions that differ significantly in size, it typically crystallizes with an FCC unit cell, like that shown in **Figure 10.60**. Sodium chloride, NaCl, is an example of this, with Na^+ and Cl^- having radii of 102 pm and 181 pm, respectively. We can think of this as chloride ions forming an FCC cell, with sodium ions located in the octahedral holes in the middle of the cell edges and in the center of the cell. The sodium and chloride ions touch each other along the cell edges. The unit cell contains four sodium ions and four chloride ions, giving the 1:1 stoichiometry required by the formula, NaCl.

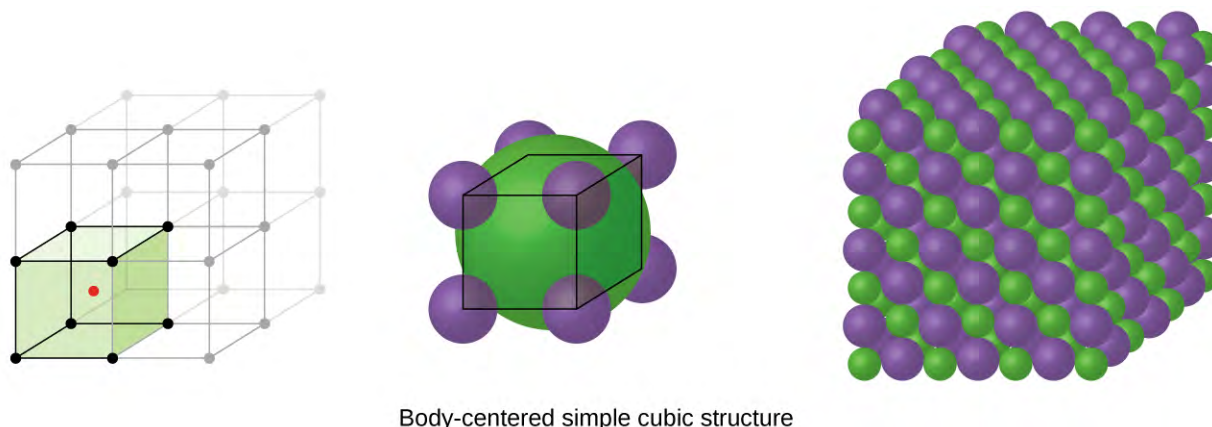

Figure 10.60 Ionic compounds with anions that are much larger than cations, such as NaCl, usually form an FCC structure. They can be described by FCC unit cells with cations in the octahedral holes.

The cubic form of zinc sulfide, zinc blende, also crystallizes in an FCC unit cell, as illustrated in **Figure 10.61**. This structure contains sulfide ions on the lattice points of an FCC lattice. (The arrangement of sulfide ions is identical to the arrangement of chloride ions in sodium chloride.) The radius of a zinc ion is only about 40% of the radius of a sulfide ion, so these small Zn^{2+} ions are located in alternating tetrahedral holes, that is, in one half of the tetrahedral holes. There are four zinc ions and four sulfide ions in the unit cell, giving the empirical formula ZnS.

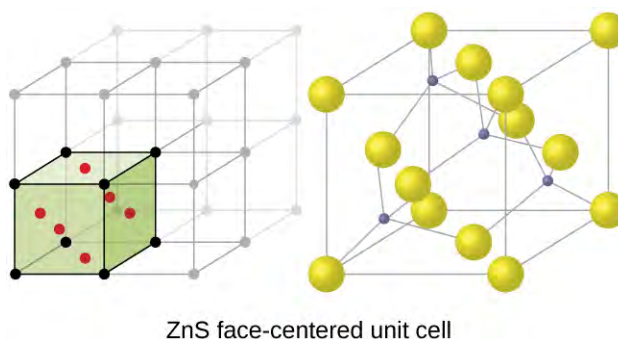
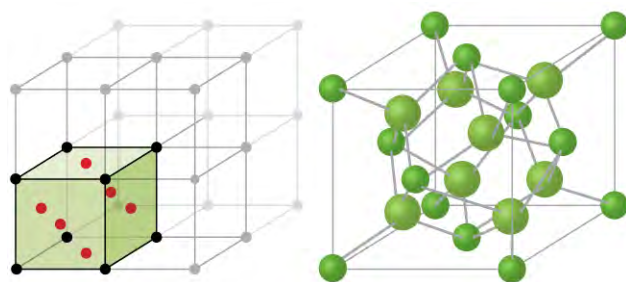

Figure 10.61 ZnS, zinc sulfide (or zinc blende) forms an FCC unit cell with sulfide ions at the lattice points and much smaller zinc ions occupying half of the tetrahedral holes in the structure.

A calcium fluoride unit cell, like that shown in **Figure 10.62**, is also an FCC unit cell, but in this case, the cations are located on the lattice points; equivalent calcium ions are located on the lattice points of an FCC lattice. All of the tetrahedral sites in the FCC array of calcium ions are occupied by fluoride ions. There are four calcium ions and eight fluoride ions in a unit cell, giving a calcium:fluorine ratio of 1:2, as required by the chemical formula, CaF_2 . Close examination of **Figure 10.62** will reveal a simple cubic array of fluoride ions with calcium ions in one half of the cubic holes. The structure cannot be described in terms of a **space lattice** of points on the fluoride ions because the

fluoride ions do not all have identical environments. The orientation of the four calcium ions about the fluoride ions differs.



CaF₂ face-centered unit cell

Figure 10.62 Calcium fluoride, CaF₂, forms an FCC unit cell with calcium ions (green) at the lattice points and fluoride ions (red) occupying all of the tetrahedral sites between them.

Calculation of Ionic Radii

If we know the edge length of a unit cell of an ionic compound and the position of the ions in the cell, we can calculate ionic radii for the ions in the compound if we make assumptions about individual ionic shapes and contacts.

Example 10.18

Calculation of Ionic Radii

The edge length of the unit cell of LiCl (NaCl-like structure, FCC) is 0.514 nm or 5.14 Å. Assuming that the lithium ion is small enough so that the chloride ions are in contact, as in **Figure 10.60**, calculate the ionic radius for the chloride ion.

Note: The length unit angstrom, Å, is often used to represent atomic-scale dimensions and is equivalent to 10⁻¹⁰ m.

Solution

On the face of a LiCl unit cell, chloride ions contact each other across the diagonal of the face:

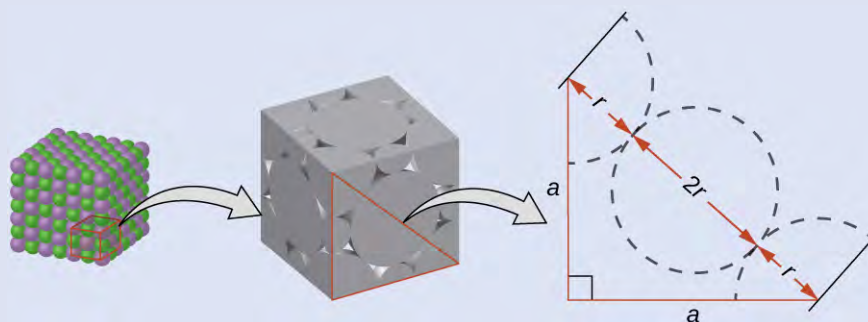

Drawing a right triangle on the face of the unit cell, we see that the length of the diagonal is equal to four chloride radii (one radius from each corner chloride and one diameter—which equals two radii—from the chloride ion in the center of the face), so $d = 4r$. From the Pythagorean theorem, we have:

$$a^2 + a^2 = d^2$$

which yields:

$$(0.514 \text{ nm})^2 + (0.514 \text{ nm})^2 = (4r)^2 = 16r^2$$

Solving this gives:

$$r = \sqrt{\frac{(0.514 \text{ nm})^2 + (0.514 \text{ nm})^2}{16}} = 0.182 \text{ nm} (1.82 \text{ \AA}) \text{ for a } \text{Cl}^- \text{ radius.}$$

Check Your Learning

The edge length of the unit cell of KCl (NaCl-like structure, FCC) is 6.28 Å. Assuming anion-cation contact along the cell edge, calculate the radius of the potassium ion. The radius of the chloride ion is 1.82 Å.

Answer: The radius of the potassium ion is 1.33 Å.

It is important to realize that values for ionic radii calculated from the edge lengths of unit cells depend on numerous assumptions, such as a perfect spherical shape for ions, which are approximations at best. Hence, such calculated values are themselves approximate and comparisons cannot be pushed too far. Nevertheless, this method has proved useful for calculating ionic radii from experimental measurements such as X-ray crystallographic determinations.

X-Ray Crystallography

The size of the unit cell and the arrangement of atoms in a crystal may be determined from measurements of the *diffraction* of X-rays by the crystal, termed **X-ray crystallography**. **Diffraction** is the change in the direction of travel experienced by an electromagnetic wave when it encounters a physical barrier whose dimensions are comparable to those of the wavelength of the light. X-rays are electromagnetic radiation with wavelengths about as long as the distance between neighboring atoms in crystals (on the order of a few Å).

When a beam of monochromatic X-rays strikes a crystal, its rays are scattered in all directions by the atoms within the crystal. When scattered waves traveling in the same direction encounter one another, they undergo *interference*, a process by which the waves combine to yield either an increase or a decrease in amplitude (intensity) depending upon the extent to which the combining waves' maxima are separated (see **Figure 10.63**).

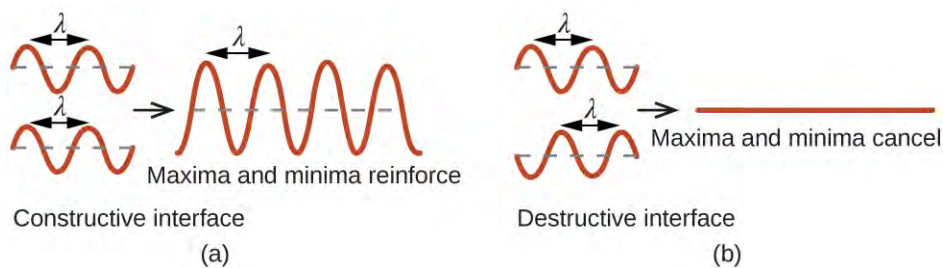

Figure 10.63 Light waves occupying the same space experience interference, combining to yield waves of greater (a) or lesser (b) intensity, depending upon the separation of their maxima and minima.

When X-rays of a certain wavelength, λ , are scattered by atoms in adjacent crystal planes separated by a distance, d , they may undergo constructive interference when the difference between the distances traveled by the two waves prior to their combination is an integer factor, n , of the wavelength. This condition is satisfied when the angle of the diffracted beam, θ , is related to the wavelength and interatomic distance by the equation:

$$n\lambda = 2d \sin \theta$$

This relation is known as the **Bragg equation** in honor of W. H. Bragg, the English physicist who first explained this phenomenon. **Figure 10.64** illustrates two examples of diffracted waves from the same two crystal planes. The figure on the left depicts waves diffracted at the Bragg angle, resulting in constructive interference, while that on the right shows diffraction and a different angle that does not satisfy the Bragg condition, resulting in destructive interference.

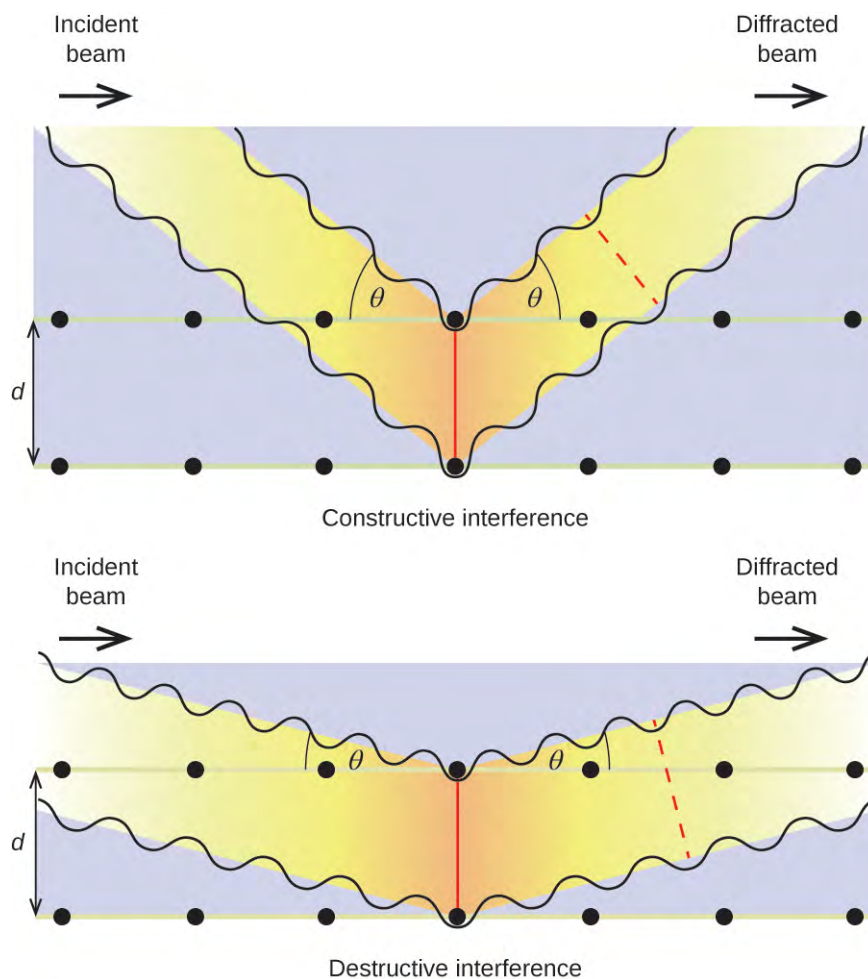

Figure 10.64 The diffraction of X-rays scattered by the atoms within a crystal permits the determination of the distance between the atoms. The top image depicts constructive interference between two scattered waves and a resultant diffracted wave of high intensity. The bottom image depicts destructive interference and a low intensity diffracted wave.

Link to Learning



Visit this [site \(http://openstaxcollege.org//16bragg\)](http://openstaxcollege.org//16bragg) for more details on the Bragg equation and a simulator that allows you to explore the effect of each variable on the intensity of the diffracted wave.

An X-ray diffractometer, such as the one illustrated in **Figure 10.65**, may be used to measure the angles at which X-rays are diffracted when interacting with a crystal as described earlier. From such measurements, the Bragg equation may be used to compute distances between atoms as demonstrated in the following example exercise.

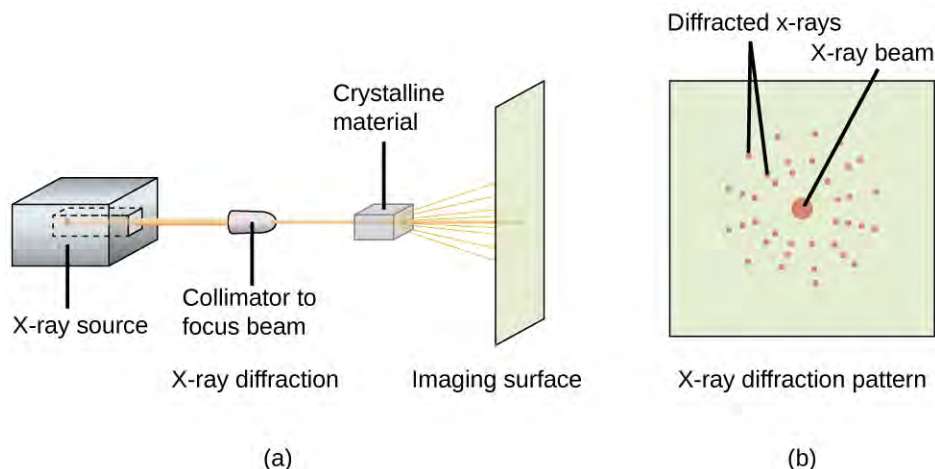

Figure 10.65 (a) In a diffractometer, a beam of X-rays strikes a crystalline material, producing (b) an X-ray diffraction pattern that can be analyzed to determine the crystal structure.

Example 10.19

Using the Bragg Equation

In a diffractometer, X-rays with a wavelength of 0.1315 nm were used to produce a diffraction pattern for copper. The first order diffraction ($n = 1$) occurred at an angle $\theta = 25.25^\circ$. Determine the spacing between the diffracting planes in copper.

Solution

The distance between the planes is found by solving the Bragg equation, $n\lambda = 2d \sin \theta$, for d .

$$\text{This gives: } d = \frac{n\lambda}{2 \sin \theta} = \frac{1(0.1315 \text{ nm})}{2 \sin (25.25^\circ)} = 0.154 \text{ nm}$$

Check Your Learning

A crystal with spacing between planes equal to 0.394 nm diffracts X-rays with a wavelength of 0.147 nm. What is the angle for the first order diffraction?

Answer: 21.9°.

Portrait of a Chemist

X-ray Crystallographer Rosalind Franklin

The discovery of the structure of DNA in 1953 by Francis Crick and James Watson is one of the great achievements in the history of science. They were awarded the 1962 Nobel Prize in Physiology or Medicine, along with Maurice Wilkins, who provided experimental proof of DNA's structure. British chemist Rosalind Franklin made invaluable contributions to this monumental achievement through her work in measuring X-ray diffraction images of DNA. Early in her career, Franklin's research on the structure of coals proved helpful to the British war effort. After shifting her focus to biological systems in the early 1950s, Franklin and doctoral student Raymond Gosling discovered that DNA consists of two forms: a long, thin fiber formed when wet (type "B") and a short, wide fiber formed when dried (type "A"). Her X-ray diffraction images of DNA (**Figure 10.66**) provided the crucial information that allowed Watson and Crick to confirm that DNA forms a double helix, and

to determine details of its size and structure. Franklin also conducted pioneering research on viruses and the RNA that contains their genetic information, uncovering new information that radically changed the body of knowledge in the field. After developing ovarian cancer, Franklin continued to work until her death in 1958 at age 37. Among many posthumous recognitions of her work, the Chicago Medical School of Finch University of Health Sciences changed its name to the Rosalind Franklin University of Medicine and Science in 2004, and adopted an image of her famous X-ray diffraction image of DNA as its official university logo.

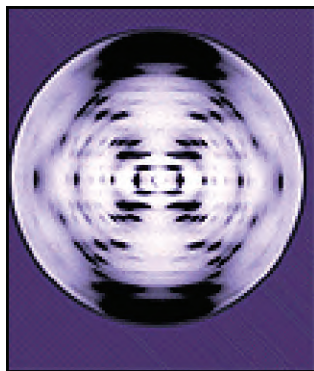

Figure 10.66 This illustration shows an X-ray diffraction image similar to the one Franklin found in her research. (credit: National Institutes of Health)

Key Terms

adhesive force force of attraction between molecules of different chemical identities

amorphous solid (also, noncrystalline solid) solid in which the particles lack an ordered internal structure

body-centered cubic (BCC) solid crystalline structure that has a cubic unit cell with lattice points at the corners and in the center of the cell

body-centered cubic unit cell simplest repeating unit of a body-centered cubic crystal; it is a cube containing lattice points at each corner and in the center of the cube

boiling point temperature at which the vapor pressure of a liquid equals the pressure of the gas above it

Bragg equation equation that relates the angles at which X-rays are diffracted by the atoms within a crystal

capillary action flow of liquid within a porous material due to the attraction of the liquid molecules to the surface of the material and to other liquid molecules

Clausius-Clapeyron equation mathematical relationship between the temperature, vapor pressure, and enthalpy of vaporization for a substance

cohesive force force of attraction between identical molecules

condensation change from a gaseous to a liquid state

coordination number number of atoms closest to any given atom in a crystal or to the central metal atom in a complex

covalent network solid solid whose particles are held together by covalent bonds

critical point temperature and pressure above which a gas cannot be condensed into a liquid

crystalline solid solid in which the particles are arranged in a definite repeating pattern

cubic closest packing (CCP) crystalline structure in which planes of closely packed atoms or ions are stacked as a series of three alternating layers of different relative orientations (ABC)

deposition change from a gaseous state directly to a solid state

diffraction redirection of electromagnetic radiation that occurs when it encounters a physical barrier of appropriate dimensions

dipole-dipole attraction intermolecular attraction between two permanent dipoles

dispersion force (also, London dispersion force) attraction between two rapidly fluctuating, temporary dipoles; significant only when particles are very close together

dynamic equilibrium state of a system in which reciprocal processes are occurring at equal rates

face-centered cubic (FCC) solid crystalline structure consisting of a cubic unit cell with lattice points on the corners and in the center of each face

face-centered cubic unit cell simplest repeating unit of a face-centered cubic crystal; it is a cube containing lattice points at each corner and in the center of each face

freezing change from a liquid state to a solid state

freezing point temperature at which the solid and liquid phases of a substance are in equilibrium; see also *melting point*

hexagonal closest packing (HCP) crystalline structure in which close packed layers of atoms or ions are stacked as a series of two alternating layers of different relative orientations (AB)

hole (also, interstice) space between atoms within a crystal

hydrogen bonding occurs when exceptionally strong dipoles attract; bonding that exists when hydrogen is bonded to one of the three most electronegative elements: F, O, or N

induced dipole temporary dipole formed when the electrons of an atom or molecule are distorted by the instantaneous dipole of a neighboring atom or molecule

instantaneous dipole temporary dipole that occurs for a brief moment in time when the electrons of an atom or molecule are distributed asymmetrically

intermolecular force noncovalent attractive force between atoms, molecules, and/or ions

interstitial sites spaces between the regular particle positions in any array of atoms or ions

ionic solid solid composed of positive and negative ions held together by strong electrostatic attractions

isomorphous possessing the same crystalline structure

melting change from a solid state to a liquid state

melting point temperature at which the solid and liquid phases of a substance are in equilibrium; see also *freezing point*

metallic solid solid composed of metal atoms

molecular solid solid composed of neutral molecules held together by intermolecular forces of attraction

normal boiling point temperature at which a liquid's vapor pressure equals 1 atm (760 torr)

octahedral hole open space in a crystal at the center of six particles located at the corners of an octahedron

phase diagram pressure-temperature graph summarizing conditions under which the phases of a substance can exist

polarizability measure of the ability of a charge to distort a molecule's charge distribution (electron cloud)

simple cubic structure crystalline structure with a cubic unit cell with lattice points only at the corners

simple cubic unit cell (also, primitive cubic unit cell) unit cell in the simple cubic structure

space lattice all points within a crystal that have identical environments

sublimation change from solid state directly to gaseous state

supercritical fluid substance at a temperature and pressure higher than its critical point; exhibits properties intermediate between those of gaseous and liquid states

surface tension energy required to increase the area, or length, of a liquid surface by a given amount

tetrahedral hole tetrahedral space formed by four atoms or ions in a crystal

triple point temperature and pressure at which the vapor, liquid, and solid phases of a substance are in equilibrium

unit cell smallest portion of a space lattice that is repeated in three dimensions to form the entire lattice

vacancy defect that occurs when a position that should contain an atom or ion is vacant

van der Waals force attractive or repulsive force between molecules, including dipole-dipole, dipole-induced dipole, and London dispersion forces; does not include forces due to covalent or ionic bonding, or the attraction between ions and molecules

vapor pressure (also, equilibrium vapor pressure) pressure exerted by a vapor in equilibrium with a solid or a liquid at a given temperature

vaporization change from liquid state to gaseous state

viscosity measure of a liquid's resistance to flow

X-ray crystallography experimental technique for determining distances between atoms in a crystal by measuring the angles at which X-rays are diffracted when passing through the crystal

Key Equations

- $h = \frac{2T \cos \theta}{r\rho g}$
- $P = Ae^{-\Delta H_{\text{vap}}/RT}$
- $\ln P = -\frac{\Delta H_{\text{vap}}}{RT} + \ln A$
- $\ln\left(\frac{P_2}{P_1}\right) = \frac{\Delta H_{\text{vap}}}{R}\left(\frac{1}{T_1} - \frac{1}{T_2}\right)$
- $n\lambda = 2d \sin \theta$

Summary

10.1 Intermolecular Forces

The physical properties of condensed matter (liquids and solids) can be explained in terms of the kinetic molecular theory. In a liquid, intermolecular attractive forces hold the molecules in contact, although they still have sufficient KE to move past each other.

Intermolecular attractive forces, collectively referred to as van der Waals forces, are responsible for the behavior of liquids and solids and are electrostatic in nature. Dipole-dipole attractions result from the electrostatic attraction of the partial negative end of one dipolar molecule for the partial positive end of another. The temporary dipole that results from the motion of the electrons in an atom can induce a dipole in an adjacent atom and give rise to the London dispersion force. London forces increase with increasing molecular size. Hydrogen bonds are a special type of dipole-dipole attraction that results when hydrogen is bonded to one of the three most electronegative elements: F, O, or N.

10.2 Properties of Liquids

The intermolecular forces between molecules in the liquid state vary depending upon their chemical identities and result in corresponding variations in various physical properties. Cohesive forces between like molecules are responsible for a liquid's viscosity (resistance to flow) and surface tension (elasticity of a liquid surface). Adhesive forces between the molecules of a liquid and different molecules composing a surface in contact with the liquid are responsible for phenomena such as surface wetting and capillary rise.

10.3 Phase Transitions

Phase transitions are processes that convert matter from one physical state into another. There are six phase transitions between the three phases of matter. Melting, vaporization, and sublimation are all endothermic processes, requiring an input of heat to overcome intermolecular attractions. The reciprocal transitions of freezing, condensation, and deposition are all exothermic processes, involving heat as intermolecular attractive forces are established or strengthened. The temperatures at which phase transitions occur are determined by the relative strengths of intermolecular attractions and are, therefore, dependent on the chemical identity of the substance.

10.4 Phase Diagrams

The temperature and pressure conditions at which a substance exists in solid, liquid, and gaseous states are summarized in a phase diagram for that substance. Phase diagrams are combined plots of three pressure-temperature equilibrium curves: solid-liquid, liquid-gas, and solid-gas. These curves represent the relationships between phase-transition temperatures and pressures. The point of intersection of all three curves represents the substance's triple point—the temperature and pressure at which all three phases are in equilibrium. At pressures below the triple point, a substance cannot exist in the liquid state, regardless of its temperature. The terminus of the liquid-gas curve represents the substance's critical point, the pressure and temperature above which a liquid phase cannot exist.

10.5 The Solid State of Matter

Some substances form crystalline solids consisting of particles in a very organized structure; others form amorphous (noncrystalline) solids with an internal structure that is not ordered. The main types of crystalline solids are ionic solids, metallic solids, covalent network solids, and molecular solids. The properties of the different kinds of crystalline solids are due to the types of particles of which they consist, the arrangements of the particles, and the strengths of the attractions between them. Because their particles experience identical attractions, crystalline solids have distinct melting temperatures; the particles in amorphous solids experience a range of interactions, so they soften gradually and melt over a range of temperatures. Some crystalline solids have defects in the definite repeating pattern of their particles. These defects (which include vacancies, atoms or ions not in the regular positions, and impurities) change physical properties such as electrical conductivity, which is exploited in the silicon crystals used to manufacture computer chips.

10.6 Lattice Structures in Crystalline Solids

The structures of crystalline metals and simple ionic compounds can be described in terms of packing of spheres. Metal atoms can pack in hexagonal closest-packed structures, cubic closest-packed structures, body-centered structures, and simple cubic structures. The anions in simple ionic structures commonly adopt one of these structures, and the cations occupy the spaces remaining between the anions. Small cations usually occupy tetrahedral holes in a closest-packed array of anions. Larger cations usually occupy octahedral holes. Still larger cations can occupy cubic holes in a simple cubic array of anions. The structure of a solid can be described by indicating the size and shape of a unit cell and the contents of the cell. The type of structure and dimensions of the unit cell can be determined by X-ray diffraction measurements.

Exercises

10.1 Intermolecular Forces

1. In terms of their bulk properties, how do liquids and solids differ? How are they similar?
2. In terms of the kinetic molecular theory, in what ways are liquids similar to solids? In what ways are liquids different from solids?
3. In terms of the kinetic molecular theory, in what ways are liquids similar to gases? In what ways are liquids different from gases?
4. Explain why liquids assume the shape of any container into which they are poured, whereas solids are rigid and retain their shape.
5. What is the evidence that all neutral atoms and molecules exert attractive forces on each other?

6. Open the **PhET States of Matter Simulation** (<http://openstaxcollege.org//16phetvisual>) to answer the following questions:

(a) Select the Solid, Liquid, Gas tab. Explore by selecting different substances, heating and cooling the systems, and changing the state. What similarities do you notice between the four substances for each phase (solid, liquid, gas)? What differences do you notice?

(b) For each substance, select each of the states and record the given temperatures. How do the given temperatures for each state correlate with the strengths of their intermolecular attractions? Explain.

(c) Select the Interaction Potential tab, and use the default neon atoms. Move the Ne atom on the right and observe how the potential energy changes. Select the Total Force button, and move the Ne atom as before. When is the total force on each atom attractive and large enough to matter? Then select the Component Forces button, and move the Ne atom. When do the attractive (van der Waals) and repulsive (electron overlap) forces balance? How does this relate to the potential energy versus the distance between atoms graph? Explain.

7. Define the following and give an example of each:

(a) dispersion force

(b) dipole-dipole attraction

(c) hydrogen bond

8. The types of intermolecular forces in a substance are identical whether it is a solid, a liquid, or a gas. Why then does a substance change phase from a gas to a liquid or to a solid?

9. Why do the boiling points of the noble gases increase in the order $\text{He} < \text{Ne} < \text{Ar} < \text{Kr} < \text{Xe}$?

10. Neon and HF have approximately the same molecular masses.

(a) Explain why the boiling points of Neon and HF differ.

(b) Compare the change in the boiling points of Ne, Ar, Kr, and Xe with the change of the boiling points of HF, HCl, HBr, and HI, and explain the difference between the changes with increasing atomic or molecular mass.

11. Arrange each of the following sets of compounds in order of increasing boiling point temperature:

(a) HCl, H₂O, SiH₄

(b) F₂, Cl₂, Br₂

(c) CH₄, C₂H₆, C₃H₈

(d) O₂, NO, N₂

12. The molecular mass of butanol, C₄H₉OH, is 74.14; that of ethylene glycol, CH₂(OH)CH₂OH, is 62.08, yet their boiling points are 117.2 °C and 174 °C, respectively. Explain the reason for the difference.

13. On the basis of intermolecular attractions, explain the differences in the boiling points of *n*-butane (−1 °C) and chloroethane (12 °C), which have similar molar masses.

14. On the basis of dipole moments and/or hydrogen bonding, explain in a qualitative way the differences in the boiling points of acetone (56.2 °C) and 1-propanol (97.4 °C), which have similar molar masses.

15. The melting point of H₂O(s) is 0 °C. Would you expect the melting point of H₂S(s) to be −85 °C, 0 °C, or 185 °C? Explain your answer.

16. Silane (SiH₄), phosphine (PH₃), and hydrogen sulfide (H₂S) melt at −185 °C, −133 °C, and −85 °C, respectively. What does this suggest about the polar character and intermolecular attractions of the three compounds?

17. Explain why a hydrogen bond between two water molecules is weaker than a hydrogen bond between two hydrogen fluoride molecules.

18. Under certain conditions, molecules of acetic acid, CH₃COOH, form “dimers,” pairs of acetic acid molecules held together by strong intermolecular attractions:

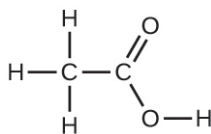

Draw a dimer of acetic acid, showing how two CH_3COOH molecules are held together, and stating the type of IMF that is responsible.

19. Proteins are chains of amino acids that can form in a variety of arrangements, one of which is a helix. What kind of IMF is responsible for holding the protein strand in this shape? On the protein image, show the locations of the IMFs that hold the protein together:

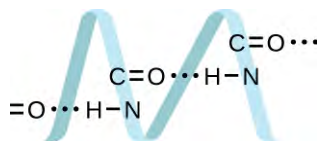

20. The density of liquid NH_3 is 0.64 g/mL; the density of gaseous NH_3 at STP is 0.0007 g/mL. Explain the difference between the densities of these two phases.

21. Identify the intermolecular forces present in the following solids:

- (a) $\text{CH}_3\text{CH}_2\text{OH}$
- (b) $\text{CH}_3\text{CH}_2\text{CH}_3$
- (c) $\text{CH}_3\text{CH}_2\text{Cl}$

10.2 Properties of Liquids

22. The test tubes shown here contain equal amounts of the specified motor oils. Identical metal spheres were dropped at the same time into each of the tubes, and a brief moment later, the spheres had fallen to the heights indicated in the illustration.

Rank the motor oils in order of increasing viscosity, and explain your reasoning:

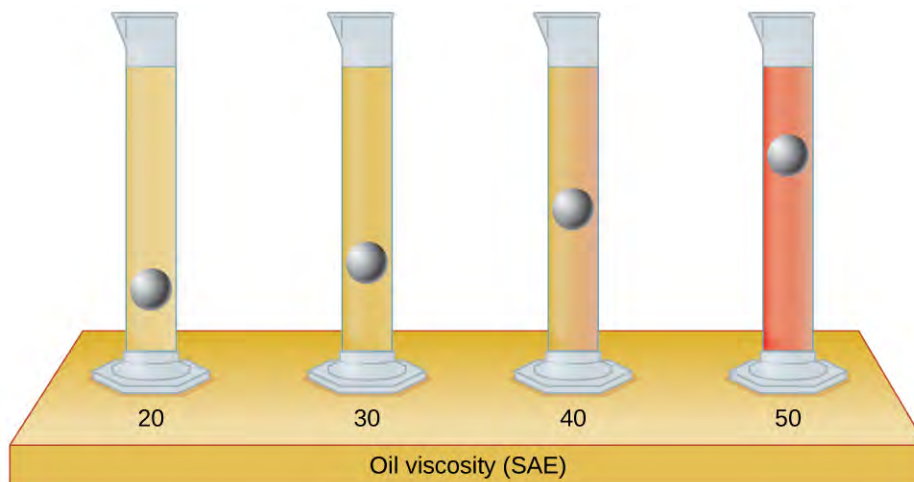

23. Although steel is denser than water, a steel needle or paper clip placed carefully lengthwise on the surface of still water can be made to float. Explain at a molecular level how this is possible:

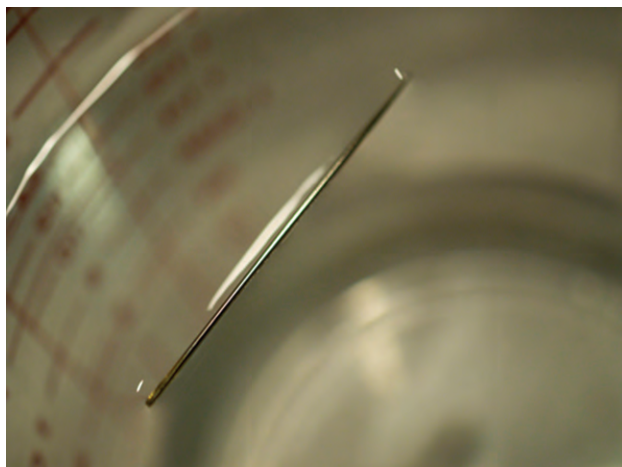

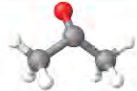

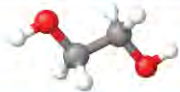

Figure 10.67 (credit: Cory Zanker)

24. The surface tension and viscosity values for diethyl ether, acetone, ethanol, and ethylene glycol are shown here.

Compound	Molecule	Surface Tension (mN/m)	Viscosity (mPa s)
diethyl ether $C_2H_5OC_2H_5$		17	0.22
acetone CH_3COCH_3		23	0.31
ethanol C_2H_5OH		22	1.07
ethylene glycol $CH_2(OH)CH_2(OH)$		48	16.1

(a) Explain their differences in viscosity in terms of the size and shape of their molecules and their IMFs.

(b) Explain their differences in surface tension in terms of the size and shape of their molecules and their IMFs:

25. You may have heard someone use the figure of speech “slower than molasses in winter” to describe a process that occurs slowly. Explain why this is an apt idiom, using concepts of molecular size and shape, molecular interactions, and the effect of changing temperature.

26. It is often recommended that you let your car engine run idle to warm up before driving, especially on cold winter days. While the benefit of prolonged idling is dubious, it is certainly true that a warm engine is more fuel efficient than a cold one. Explain the reason for this.

27. The surface tension and viscosity of water at several different temperatures are given in this table.

Water	Surface Tension (mN/m)	Viscosity (mPa s)
0 °C	75.6	1.79
20 °C	72.8	1.00
60 °C	66.2	0.47
100 °C	58.9	0.28

(a) As temperature increases, what happens to the surface tension of water? Explain why this occurs, in terms of molecular interactions and the effect of changing temperature.

(b) As temperature increases, what happens to the viscosity of water? Explain why this occurs, in terms of molecular interactions and the effect of changing temperature.

28. At 25 °C, how high will water rise in a glass capillary tube with an inner diameter of 0.63 mm? Refer to **Example 10.4** for the required information.

29. Water rises in a glass capillary tube to a height of 17 cm. What is the diameter of the capillary tube?

10.3 Phase Transitions

30. Heat is added to boiling water. Explain why the temperature of the boiling water does not change. What does change?

31. Heat is added to ice at 0 °C. Explain why the temperature of the ice does not change. What does change?

32. What feature characterizes the dynamic equilibrium between a liquid and its vapor in a closed container?

33. Identify two common observations indicating some liquids have sufficient vapor pressures to noticeably evaporate?

34. Identify two common observations indicating some solids, such as dry ice and mothballs, have vapor pressures sufficient to sublime?

35. What is the relationship between the intermolecular forces in a liquid and its vapor pressure?

36. What is the relationship between the intermolecular forces in a solid and its melting temperature?

37. Why does spilled gasoline evaporate more rapidly on a hot day than on a cold day?

38. Carbon tetrachloride, CCl_4 , was once used as a dry cleaning solvent, but is no longer used because it is carcinogenic. At 57.8 °C, the vapor pressure of CCl_4 is 54.0 kPa, and its enthalpy of vaporization is 33.05 kJ/mol. Use this information to estimate the normal boiling point for CCl_4 .

39. When is the boiling point of a liquid equal to its normal boiling point?

40. How does the boiling of a liquid differ from its evaporation?

41. Use the information in **Figure 10.24** to estimate the boiling point of water in Denver when the atmospheric pressure is 83.3 kPa.

42. A syringe at a temperature of 20 °C is filled with liquid ether in such a way that there is no space for any vapor. If the temperature is kept constant and the plunger is withdrawn to create a volume that can be occupied by vapor, what would be the approximate pressure of the vapor produced?

43. Explain the following observations:

(a) It takes longer to cook an egg in Ft. Davis, Texas (altitude, 5000 feet above sea level) than it does in Boston (at sea level).

(b) Perspiring is a mechanism for cooling the body.

44. The enthalpy of vaporization of water is larger than its enthalpy of fusion. Explain why.

45. Explain why the molar enthalpies of vaporization of the following substances increase in the order $\text{CH}_4 < \text{C}_2\text{H}_6 < \text{C}_3\text{H}_8$, even though the type of IMF (dispersion) is the same.

46. Explain why the enthalpies of vaporization of the following substances increase in the order $\text{CH}_4 < \text{NH}_3 < \text{H}_2\text{O}$, even though all three substances have approximately the same molar mass.
47. The enthalpy of vaporization of $\text{CO}_2(l)$ is 9.8 kJ/mol. Would you expect the enthalpy of vaporization of $\text{CS}_2(l)$ to be 28 kJ/mol, 9.8 kJ/mol, or -8.4 kJ/mol? Discuss the plausibility of each of these answers.
48. The hydrogen fluoride molecule, HF, is more polar than a water molecule, H_2O (for example, has a greater dipole moment), yet the molar enthalpy of vaporization for liquid hydrogen fluoride is lesser than that for water. Explain.
49. Ethyl chloride (boiling point, 13 °C) is used as a local anesthetic. When the liquid is sprayed on the skin, it cools the skin enough to freeze and numb it. Explain the cooling effect of liquid ethyl chloride.
50. Which contains the compounds listed correctly in order of increasing boiling points?
- (a) $\text{N}_2 < \text{CS}_2 < \text{H}_2\text{O} < \text{KCl}$
- (b) $\text{H}_2\text{O} < \text{N}_2 < \text{CS}_2 < \text{KCl}$
- (c) $\text{N}_2 < \text{KCl} < \text{CS}_2 < \text{H}_2\text{O}$
- (d) $\text{CS}_2 < \text{N}_2 < \text{KCl} < \text{H}_2\text{O}$
- (e) $\text{KCl} < \text{H}_2\text{O} < \text{CS}_2 < \text{N}_2$
51. How much heat is required to convert 422 g of liquid H_2O at 23.5 °C into steam at 150 °C?
52. Evaporation of sweat requires energy and thus take excess heat away from the body. Some of the water that you drink may eventually be converted into sweat and evaporate. If you drink a 20-ounce bottle of water that had been in the refrigerator at 3.8 °C, how much heat is needed to convert all of that water into sweat and then to vapor?? (Note: Your body temperature is 36.6 °C. For the purpose of solving this problem, assume that the thermal properties of sweat are the same as for water.)
53. Titanium tetrachloride, TiCl_4 , has a melting point of -23.2 °C and has a $\Delta H_{\text{fusion}} = 9.37$ kJ/mol.
- (a) How much energy is required to melt 263.1 g TiCl_4 ?
- (b) For TiCl_4 , which will likely have the larger magnitude: ΔH_{fusion} or $\Delta H_{\text{vaporization}}$? Explain your reasoning.

10.4 Phase Diagrams

54. From the phase diagram for water (Figure 10.31), determine the state of water at:
- (a) 35 °C and 85 kPa
- (b) -15 °C and 40 kPa
- (c) -15 °C and 0.1 kPa
- (d) 75 °C and 3 kPa
- (e) 40 °C and 0.1 kPa
- (f) 60 °C and 50 kPa
55. What phase changes will take place when water is subjected to varying pressure at a constant temperature of 0.005 °C? At 40 °C? At -40 °C?
56. Pressure cookers allow food to cook faster because the higher pressure inside the pressure cooker increases the boiling temperature of water. A particular pressure cooker has a safety valve that is set to vent steam if the pressure exceeds 3.4 atm. What is the approximate maximum temperature that can be reached inside this pressure cooker? Explain your reasoning.
57. From the phase diagram for carbon dioxide in Figure 10.34, determine the state of CO_2 at:
- (a) 20 °C and 1000 kPa
- (b) 10 °C and 2000 kPa
- (c) 10 °C and 100 kPa
- (d) -40 °C and 500 kPa

(e) $-80\text{ }^{\circ}\text{C}$ and 1500 kPa

(f) $-80\text{ }^{\circ}\text{C}$ and 10 kPa

58. Determine the phase changes that carbon dioxide undergoes as the pressure changes if the temperature is held at $-50\text{ }^{\circ}\text{C}$? If the temperature is held at $-40\text{ }^{\circ}\text{C}$? At $20\text{ }^{\circ}\text{C}$? (See the phase diagram in **Figure 10.34**.)

59. Consider a cylinder containing a mixture of liquid carbon dioxide in equilibrium with gaseous carbon dioxide at an initial pressure of 65 atm and a temperature of $20\text{ }^{\circ}\text{C}$. Sketch a plot depicting the change in the cylinder pressure with time as gaseous carbon dioxide is released at constant temperature.

60. Dry ice, $\text{CO}_2(\text{s})$, does not melt at atmospheric pressure. It sublimates at a temperature of $-78\text{ }^{\circ}\text{C}$. What is the lowest pressure at which $\text{CO}_2(\text{s})$ will melt to give $\text{CO}_2(\text{l})$? At approximately what temperature will this occur? (See **Figure 10.34** for the phase diagram.)

61. If a severe storm results in the loss of electricity, it may be necessary to use a clothesline to dry laundry. In many parts of the country in the dead of winter, the clothes will quickly freeze when they are hung on the line. If it does not snow, will they dry anyway? Explain your answer.

62. Is it possible to liquefy nitrogen at room temperature (about $25\text{ }^{\circ}\text{C}$)? Is it possible to liquefy sulfur dioxide at room temperature? Explain your answers.

63. Elemental carbon has one gas phase, one liquid phase, and three different solid phases, as shown in the phase diagram:

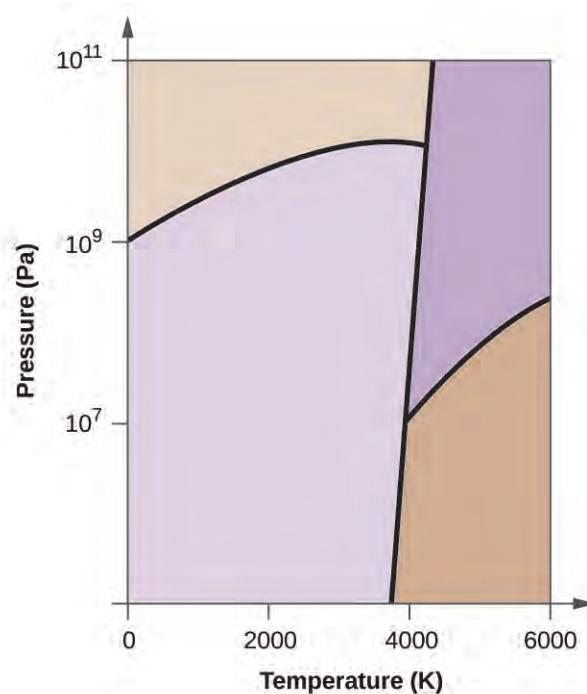

(a) On the phase diagram, label the gas and liquid regions.

(b) Graphite is the most stable phase of carbon at normal conditions. On the phase diagram, label the graphite phase.

(c) If graphite at normal conditions is heated to 2500 K while the pressure is increased to 10^{10} Pa , it is converted into diamond. Label the diamond phase.

(d) Circle each triple point on the phase diagram.

(e) In what phase does carbon exist at 5000 K and 10^8 Pa ?

(f) If the temperature of a sample of carbon increases from 3000 K to 5000 K at a constant pressure of 10^6 Pa , which phase transition occurs, if any?

10.5 The Solid State of Matter

64. What types of liquids typically form amorphous solids?

65. At very low temperatures oxygen, O_2 , freezes and forms a crystalline solid. Which best describes these crystals?

- (a) ionic
- (b) covalent network
- (c) metallic
- (d) amorphous
- (e) molecular crystals

66. As it cools, olive oil slowly solidifies and forms a solid over a range of temperatures. Which best describes the solid?

- (a) ionic
- (b) covalent network
- (c) metallic
- (d) amorphous
- (e) molecular crystals

67. Explain why ice, which is a crystalline solid, has a melting temperature of $0\text{ }^\circ\text{C}$, whereas butter, which is an amorphous solid, softens over a range of temperatures.

68. Identify the type of crystalline solid (metallic, network covalent, ionic, or molecular) formed by each of the following substances:

- (a) SiO_2
- (b) KCl
- (c) Cu
- (d) CO_2
- (e) C (diamond)
- (f) $BaSO_4$
- (g) NH_3
- (h) NH_4F
- (i) C_2H_5OH

69. Identify the type of crystalline solid (metallic, network covalent, ionic, or molecular) formed by each of the following substances:

- (a) $CaCl_2$
- (b) SiC
- (c) N_2
- (d) Fe
- (e) C (graphite)
- (f) $CH_3CH_2CH_2CH_3$
- (g) HCl
- (h) NH_4NO_3
- (i) K_3PO_4

70. Classify each substance in the table as either a metallic, ionic, molecular, or covalent network solid:

Substance	Appearance	Melting Point	Electrical Conductivity	Solubility in Water
X	lustrous, malleable	1500 °C	high	insoluble
Y	soft, yellow	113 °C	none	insoluble
Z	hard, white	800 °C	only if melted/dissolved	soluble

71. Classify each substance in the table as either a metallic, ionic, molecular, or covalent network solid:

Substance	Appearance	Melting Point	Electrical Conductivity	Solubility in Water
X	brittle, white	800 °C	only if melted/dissolved	soluble
Y	shiny, malleable	1100 °C	high	insoluble
Z	hard, colorless	3550 °C	none	insoluble

72. Identify the following substances as ionic, metallic, covalent network, or molecular solids:

Substance A is malleable, ductile, conducts electricity well, and has a melting point of 1135 °C. Substance B is brittle, does not conduct electricity as a solid but does when molten, and has a melting point of 2072 °C. Substance C is very hard, does not conduct electricity, and has a melting point of 3440 °C. Substance D is soft, does not conduct electricity, and has a melting point of 185 °C.

73. Substance A is shiny, conducts electricity well, and melts at 975 °C. Substance A is likely a(n):

- (a) ionic solid
- (b) metallic solid
- (c) molecular solid
- (d) covalent network solid

74. Substance B is hard, does not conduct electricity, and melts at 1200 °C. Substance B is likely a(n):

- (a) ionic solid
- (b) metallic solid
- (c) molecular solid
- (d) covalent network solid

10.6 Lattice Structures in Crystalline Solids

75. Describe the crystal structure of iron, which crystallizes with two equivalent metal atoms in a cubic unit cell.

76. Describe the crystal structure of Pt, which crystallizes with four equivalent metal atoms in a cubic unit cell.

77. What is the coordination number of a chromium atom in the body-centered cubic structure of chromium?

78. What is the coordination number of an aluminum atom in the face-centered cubic structure of aluminum?

79. Cobalt metal crystallizes in a hexagonal closest packed structure. What is the coordination number of a cobalt atom?

80. Nickel metal crystallizes in a cubic closest packed structure. What is the coordination number of a nickel atom?

81. Tungsten crystallizes in a body-centered cubic unit cell with an edge length of 3.165 Å.

(a) What is the atomic radius of tungsten in this structure?

(b) Calculate the density of tungsten.

82. Platinum (atomic radius = 1.38 Å) crystallizes in a cubic closely packed structure. Calculate the edge length of the face-centered cubic unit cell and the density of platinum.

83. Barium crystallizes in a body-centered cubic unit cell with an edge length of 5.025 Å

(a) What is the atomic radius of barium in this structure?

(b) Calculate the density of barium.

84. Aluminum (atomic radius = 1.43 Å) crystallizes in a cubic closely packed structure. Calculate the edge length of the face-centered cubic unit cell and the density of aluminum.

85. The density of aluminum is 2.7 g/cm³; that of silicon is 2.3 g/cm³. Explain why Si has the lower density even though it has heavier atoms.

86. The free space in a metal may be found by subtracting the volume of the atoms in a unit cell from the volume of the cell. Calculate the percentage of free space in each of the three cubic lattices if all atoms in each are of equal size and touch their nearest neighbors. Which of these structures represents the most efficient packing? That is, which packs with the least amount of unused space?

87. Cadmium sulfide, sometimes used as a yellow pigment by artists, crystallizes with cadmium, occupying one-half of the tetrahedral holes in a closest packed array of sulfide ions. What is the formula of cadmium sulfide? Explain your answer.

88. A compound of cadmium, tin, and phosphorus is used in the fabrication of some semiconductors. It crystallizes with cadmium occupying one-fourth of the tetrahedral holes and tin occupying one-fourth of the tetrahedral holes in a closest packed array of phosphide ions. What is the formula of the compound? Explain your answer.

89. What is the formula of the magnetic oxide of cobalt, used in recording tapes, that crystallizes with cobalt atoms occupying one-eighth of the tetrahedral holes and one-half of the octahedral holes in a closely packed array of oxide ions?

90. A compound containing zinc, aluminum, and sulfur crystallizes with a closest-packed array of sulfide ions. Zinc ions are found in one-eighth of the tetrahedral holes and aluminum ions in one-half of the octahedral holes. What is the empirical formula of the compound?

91. A compound of thallium and iodine crystallizes in a simple cubic array of iodide ions with thallium ions in all of the cubic holes. What is the formula of this iodide? Explain your answer.

92. Which of the following elements reacts with sulfur to form a solid in which the sulfur atoms form a closest-packed array with all of the octahedral holes occupied: Li, Na, Be, Ca, or Al?

93. What is the percent by mass of titanium in rutile, a mineral that contains titanium and oxygen, if structure can be described as a closest packed array of oxide ions with titanium ions in one-half of the octahedral holes? What is the oxidation number of titanium?

94. Explain why the chemically similar alkali metal chlorides NaCl and CsCl have different structures, whereas the chemically different NaCl and MnS have the same structure.

95. As minerals were formed from the molten magma, different ions occupied the same sites in the crystals. Lithium often occurs along with magnesium in minerals despite the difference in the charge on their ions. Suggest an explanation.

96. Rubidium iodide crystallizes with a cubic unit cell that contains iodide ions at the corners and a rubidium ion in the center. What is the formula of the compound?

97. One of the various manganese oxides crystallizes with a cubic unit cell that contains manganese ions at the corners and in the center. Oxide ions are located at the center of each edge of the unit cell. What is the formula of the compound?

98. NaH crystallizes with the same crystal structure as NaCl. The edge length of the cubic unit cell of NaH is 4.880 Å.

(a) Calculate the ionic radius of H⁻. (The ionic radius of Li⁺ is 0.095 Å.)

(b) Calculate the density of NaH.

- 99.** Thallium(I) iodide crystallizes with the same structure as CsCl. The edge length of the unit cell of TlI is 4.20 Å. Calculate the ionic radius of Tl^+ . (The ionic radius of I^- is 2.16 Å.)
- 100.** A cubic unit cell contains manganese ions at the corners and fluoride ions at the center of each edge.
- What is the empirical formula of this compound? Explain your answer.
 - What is the coordination number of the Mn^{3+} ion?
 - Calculate the edge length of the unit cell if the radius of a Mn^{3+} ion is 0.65 Å.
 - Calculate the density of the compound.
- 101.** What is the spacing between crystal planes that diffract X-rays with a wavelength of 1.541 nm at an angle θ of 15.55° (first order reflection)?
- 102.** A diffractometer using X-rays with a wavelength of 0.2287 nm produced first-order diffraction peak for a crystal angle $\theta = 16.21^\circ$. Determine the spacing between the diffracting planes in this crystal.
- 103.** A metal with spacing between planes equal to 0.4164 nm diffracts X-rays with a wavelength of 0.2879 nm. What is the diffraction angle for the first order diffraction peak?
- 104.** Gold crystallizes in a face-centered cubic unit cell. The second-order reflection ($n = 2$) of X-rays for the planes that make up the tops and bottoms of the unit cells is at $\theta = 22.20^\circ$. The wavelength of the X-rays is 1.54 Å. What is the density of metallic gold?
- 105.** When an electron in an excited molybdenum atom falls from the L to the K shell, an X-ray is emitted. These X-rays are diffracted at an angle of 7.75° by planes with a separation of 2.64 Å. What is the difference in energy between the K shell and the L shell in molybdenum assuming a first-order diffraction?

